



KRAFTSTOFFMANAGEMENT-SYSTEM



ABGABEEINHEITEN



KITS



PUMPEN



ZÄHLER



ZAPEVENTIL

PANTHER EX 56 DRUM



MERKMALE

- ROBUSTE STRUKTUR
- GEFLANSCHTE KOMPONENTEN
- HOHER DURCHFLUSS
- INTENSIVE NUTZUNG
- KONTINUIERLICHER BETRIEB
- MAGNETSCHALTER

PIUSI PANTHER EX 56 DRUM ist ein komplettes Übertragungs-kit, das speziell für die ATEX/IECEX-Konformität entwickelt wurde. Dank der Flanschkomponenten ermöglicht dieses Übertragungs-kit den Austausch von Komponenten ohne den Einsatz von Dichtmitteln, was maximale Vielseitigkeit und Anpassungsfähigkeit an jede Art von Bedingung gewährleistet.



PANTHER EX 56 DRUM
FO0582000



PANTHER EX 56 DRUM
FO0582010

LEISTUNGSPARAMETER

BIS ZU

50 L/MIN

VOLUMENSTROM

1100 MM

SAUGROHR

±1%

GENAUIGKEIT

10µm (85%)

FILTERKAPAZITÄT



UNSERE PUMPEN BESITZEN DIE FOLGENDEN ATEX-/IECEX-KLASSIFIZIERUNGEN:

II	2	G	Ex	d	IIA	T4	Gb
GRUPPE	KATEGORIE	ART DER EXPLOSIONSGEFÄHRDETEN ATMOSPHERE	PERMANENTES PRAFIX	SCHUTZ-METHODE	GAS GGLAS	TEMPERATUR-KLASSE	GERÄTESCHUTZSTUFE

VERPACKUNG

CODE	GEWICHT		VERPACKUNG		
	KG	LBS	MM	ZOLL	STCK./KARTON
FO0582000	18,3	40,3	400X240X300	15,7X9,4X11,8	1
FO0582010	21	46,2	400X240X300	15,7X9,4X11,8	1



FILTERUNG



TANKÜBERWACHUNG



SCHLAUCHAUFROLLER



ZUBEHÖR



MERCHANDISE



ANY BIODIESEL



LUFT



FROSTSCHUTZ



AdBlue®



BIODIESEL



DIESEL



LEBENS.M.



BENZIN



SCHMIERM.



KEROSIN



ÖL



WASSER



WISCHERFLÜSS.

KENNLINIEN

PANTHER EX 56

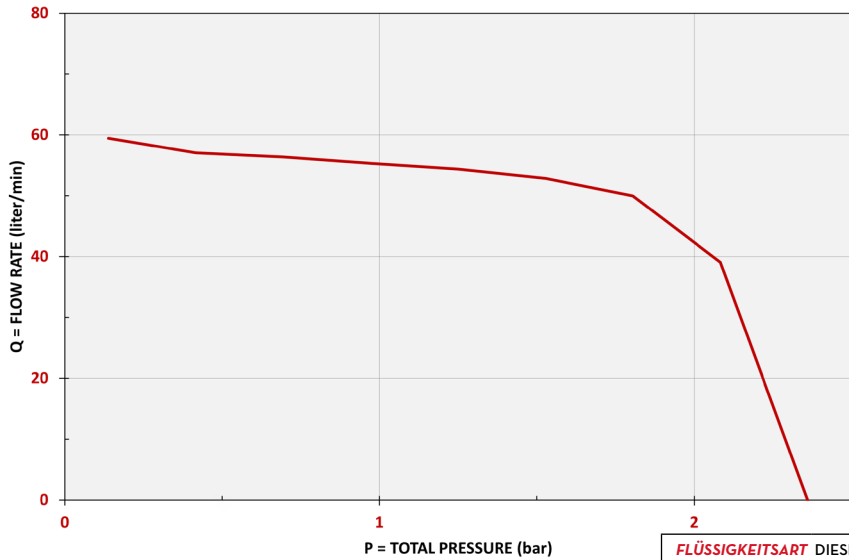

FLÜSSIGKEITSART DIESEL
TEMPERATUR 20°C

LIEFERUMFANG

- TELESKOPISCHES ANSAUGROHR
- DRUM-ANSCHLUSS
- PANTHER EX 56 PUMPE
- MECHANISCHER K33-ZÄHLER (AUF ANFRAGE)
- BENZINFILTER E25
- DRUCKSCHLAUCH
- AUTOMATISCHE ZAPFPISTOLE A60 ATEX
- BEDIENUNGSANLEITUNG

EINZELHEITEN



ZAPFVENTIL A60 ATEX



GASOLINE FILTER E25 ATEX



KNICKSCHUTZ



AUSFAHRBARES SAUGROHR

ABMESSUNGEN

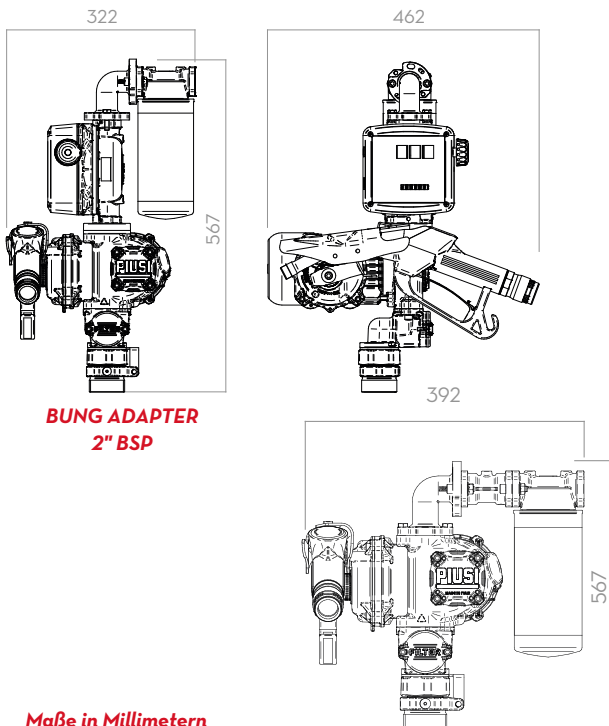

BUNG ADAPTER
2" BSP

BUNG ADAPTER
2" BSP

Maße in Millimetern

MATERIALIEN

- PUMPE:
PANTHER EX 56
- ZÄHLER:
K33 ATEX
- AUTOMATISCH ZAPFVENTIL:
A60 ATEX
- FILTER:
GASOLINE FILTER E25 ATEX

TECHNISCHE DATEN

CODE	BESCHREIBUNG	FLÜSSIGKEITSART	VOLUMENSTROM		SPANNUNG			ZÄHLER	ZAPFVENTIL	FILTRE	SCHLAUCH	
			L/MIN	GPM	AC V/Hz	STROM. WATT	AMP. MAX.				TYP	LÄNGE (M)
FO0582000	(EX) DRUM PANTHER EX 56 230V/50 AUTO/F		56	15	230V/50HZ	500	2.3	-	A60 ATEX	JA	4	20
FO0582010	(EX) DRUM PANTHER EX 56 230V/50 K33 AUT/F		56	15	230V/50HZ	500	2.3	K33 ATEX	A60 ATEX	JA	4	20

(*) VERFÜGBAR MIT VERSCHIEDENEN SPANNUNGEN UND 60-HZ-FREQUENZEN.