

Technical Specifications

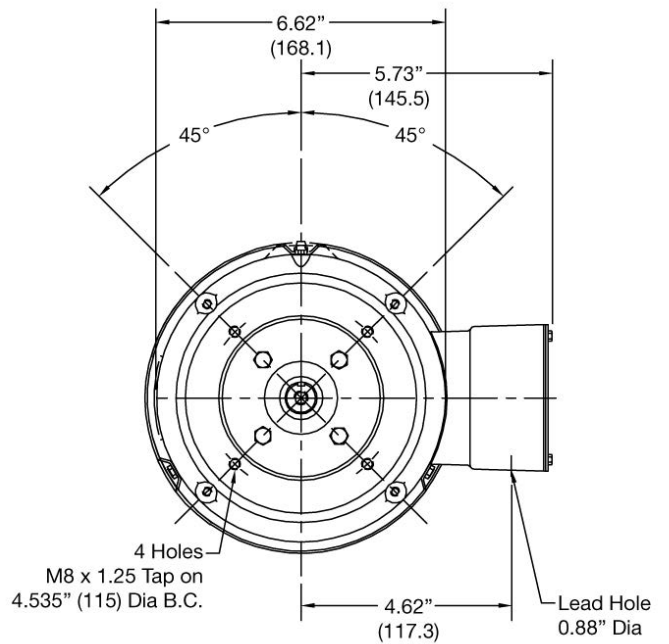

Enclosure:	TEFC (IP54)
Washdown:	No
Voltage:	190/380//230/460
Horsepower (KW):	0.75 (.56)
Phase:	3
Amps:	4.2/2.1//4/2
Frequency:	50-60 Hz
Insulation Class:	F
Power Factor:	.49
Frame:	D90LC
RPM:	750-900
Noise Level:	70 dBa
Certification:	UL & CSA
Weight:	56 lbs (25,5 kg)

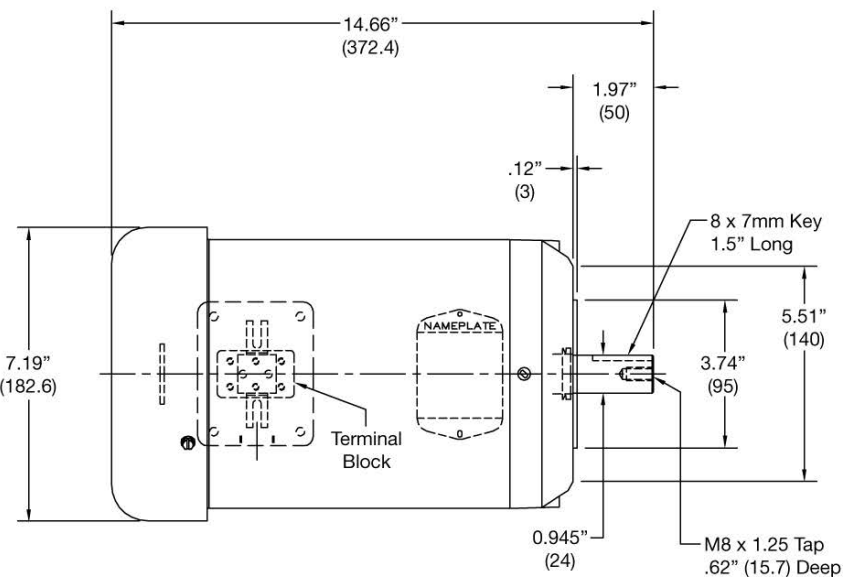

WARNING: Not suitable for pumping flammable or combustible liquids or use in a hazardous duty environment.

Note: Only compatible with the SP-700DD or 800DD Series pump.