

DELIVERY

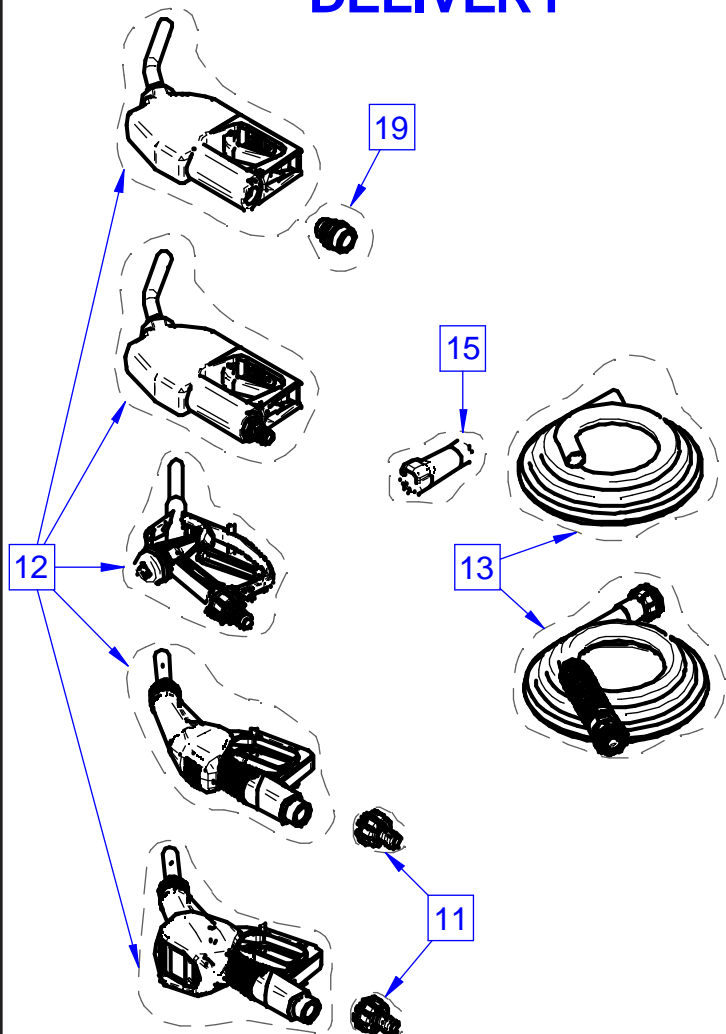

SUCTION

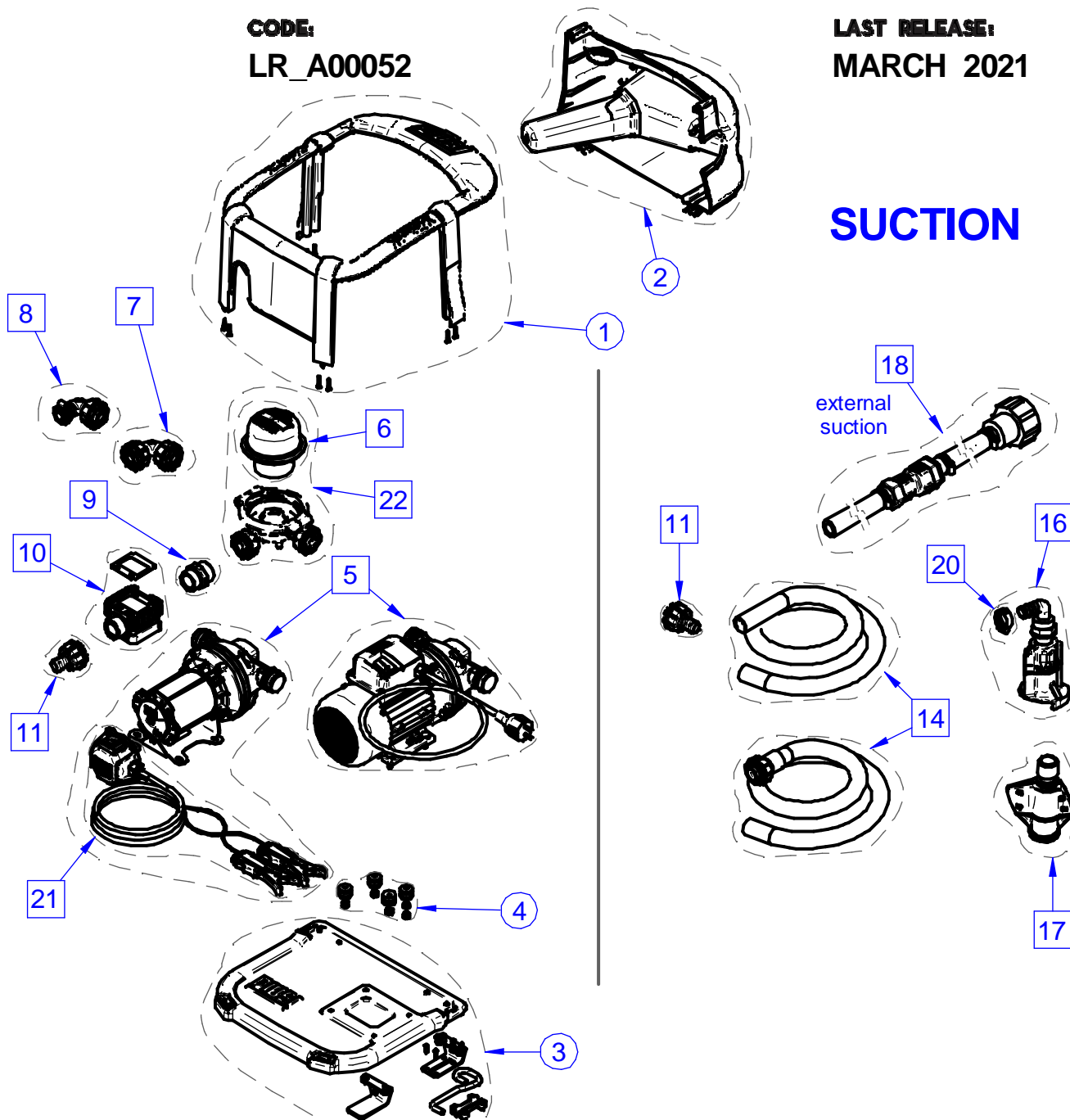

Some components may vary in shape and color or not be present. Always follow codes and quantity shown in list. ○ fixed components □ variable components - - - only reference

Ersatzteil

| | | |
|------------------|----|--|
| R18678000 | 1 | FRAMEWORK KIT "THREE25"* |
| R18677000 | 2 | CASE KIT THREE25* |
| R18682000 | 3 | BASE KIT THREE25* |
| R16450000 | 4 | FIXING SCREW KIT THREE25 PUMP* |
| F00203090 | 5 | SUZZARABLUE PUMP 230V/50 2 MT CABLE* |
| F00611D40 | 6 | PIUSI 3D FILTER CARTRIDGE* |
| F15452000 | 16 | SEC CONNECTOR + HOSE TAIL 90° M 3/4** |
| F00611D30 | 22 | PIUSI 3D FILTER + HOUSING* |
| F0040710A | 10 | K24 METER ADBLUE 1" M/F BSP* |
| F0061700A | 12 | AUTOMATIC NOZZLE SB325_X* |
| F1907200A | 13 | DELIVERY EPDM CRIMPED HOSE F 3/4" BSP 6MT* |
| F19286000 | 14 | SUCTION PVC HOSE 3/4" 1.5MT CRIMP 1 SIDE* |
| F13800000 | 20 | STAINLESS STEEL CLAMPS (10PCS)* |