



RIFORMIMENTO  
AUTO



FUEL MANAGEMENT  
SYSTEMS



KITS



POMPE



CONTALTRI



PISTOLE  
CONTALTRI

# SUZZARABLUE PUMP DC

## CARATTERISTICHE

- PRONTO ALL'USO
- POMPA MULTIUSO
- AUTOADESCANTE
- VALVOLA BYPASS INCORPORATA

SUZZARABLUE PUMP DC di PIUSI è una pompa a membrana elettrica adatta per il travaso dell'AdBlue®. Questa pompa autoadescente è dotata di un bypass di pressione incorporato.

## PERFORMANCE

FINO A

**35 L/MIN**

PORTATA

**20 MIN**

CICLO DI LAVORO



SUZZARABLUE PUMP DC



## PACKAGING

CODICE	PESO		PACKAGING		N. BOX/EUROPALLET	
	KG	LBS	MM	PEZZI/BOX		
FO0204080	3,6	7,9	350X180X280	1	60	84
FO0204090	3,6	7,9	350X180X280	1	60	84



PISTOLE



FILTRAZIONE



MONITORAGGIO FLUIDI



ARROTOLATORI



ACCESSORI



MERCHANDISE



ARIA



ANTIGELO



AdBlue®



BIODIESEL



DIESEL



ALIMENTI



BENZINA



GRASSO



KEROSENE



OLIO



ACQUA



LAVAVETRI

## GRAFICO

### SUZZARBLUE DC

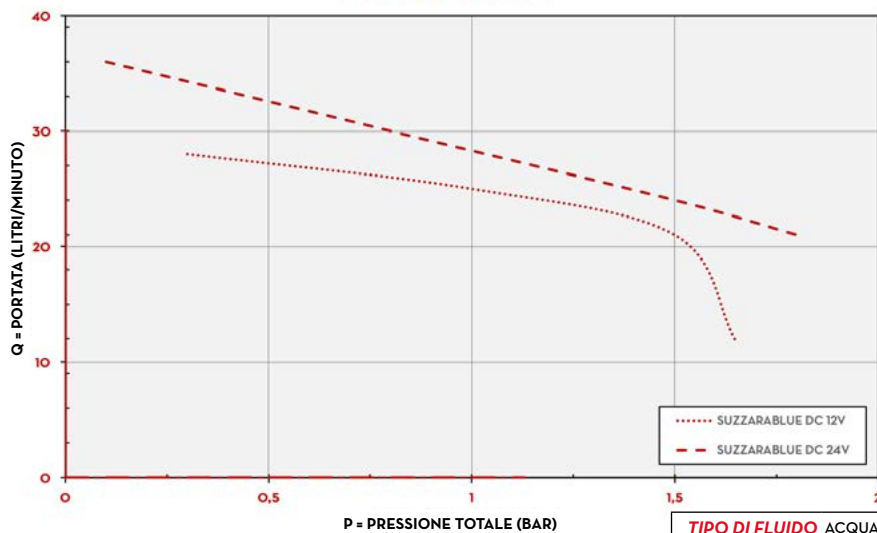

TIPO DI FLUIDO ACQUA

TEMPERATURA 20°C

## DIMENSIONI

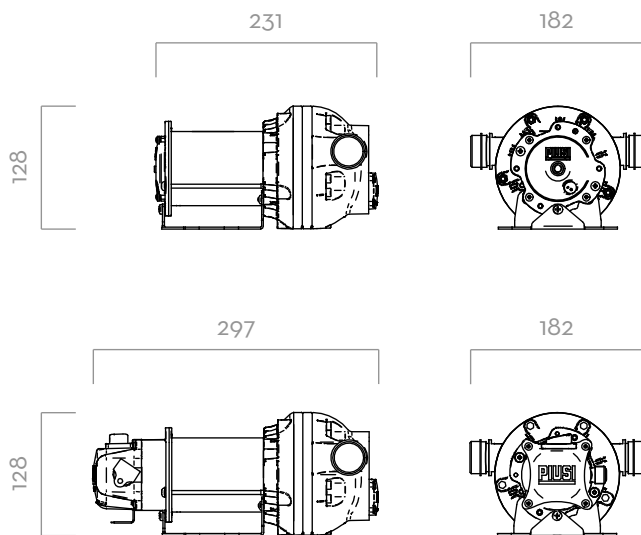

Dimensioni espresse in millimetri

## DENTRO LA SCATOLA

- SUZZARBLUE PUMP DC
- MORSETTI
- MANUALE ISTRUZIONI

## DETTAGLI



ON/OFF INTERRUPTORE



MORSETTI

## MATERIALI

- CORPO: POLIPROPILENE
- MEMBRANA: POLIPROPILENE

## DATI TECNICI

CODICE	DESCRIZIONE	TIPI DI FLUIDO	PORTATA		VOLTAGGIO				CAVI MOD.	INLET-OUTLET BSP	ON/OFF INTERRUPTORE
			L/MIN	GPM	AC V/HZ DC VOLT	RPM	POTENZA WATT	AMP. MAX.			
FOO204080	SUZZARBLUE DC PUMP 12V		35	9,2	12	2600	260	22	SI	3/4"	SI
FOO204090	SUZZARBLUE DC PUMP 24V		35	9,2	24	2600	310	10	SI	3/4"	SI