



RAVITAILLEMENT DES
AUTOMOBILES



SYSTÈMES DE GESTION
DU CARBURANT



KITS



POMPES



COMPTEURS



PISTOLETS COMPTEURS

SUZZARABLUE PUMP DC

CARACTÉRISTIQUES

- PRÊTE À L'USAGE
- POMPE MULTI-USAGES
- AUTO-AMORÇANTE
- VANNE DE DÉRIVATION INTÉGRÉE

PIUSI SUZZARABLUE PUMP DC de PIUSI est une pompe à diaphragme électrique DC adaptée pour le transvasement d'AdBlue®. Cette pompe auto-amorçante est dotée d'une dérivation de pression intégrée.

PERFORMANCES

JUSQU'À

35 L/MIN

DÉBIT

20 MIN

CYCLE DE SERVICE



SUZZARABLUE PUMP DC



PACKAGING

CODE	POIDS		PACKAGING		N. BOXES/EUROPALLET	
	KG	LBS	MM	PCS/BOÎTE		
FO0204080	3,6	7,9	350X180X280	1	60	84
FO0204090	3,6	7,9	350X180X280	1	60	84



PISTOLETS



FILTRAGE

SURVEILLANCE
DES LIQUIDES

ENROULEURS



ACCESSOIRES



MERCHANDISE



AIR



ANTIGEL



AdBlue®



BIODIESEL



DIESEL



ALIMENTATION



ESSENCE



GRAISSE



KÉROSÈNE



HUILE



EAU



LAVE-GLACE

GRAPHIQUES

SUZZARBLUE DC

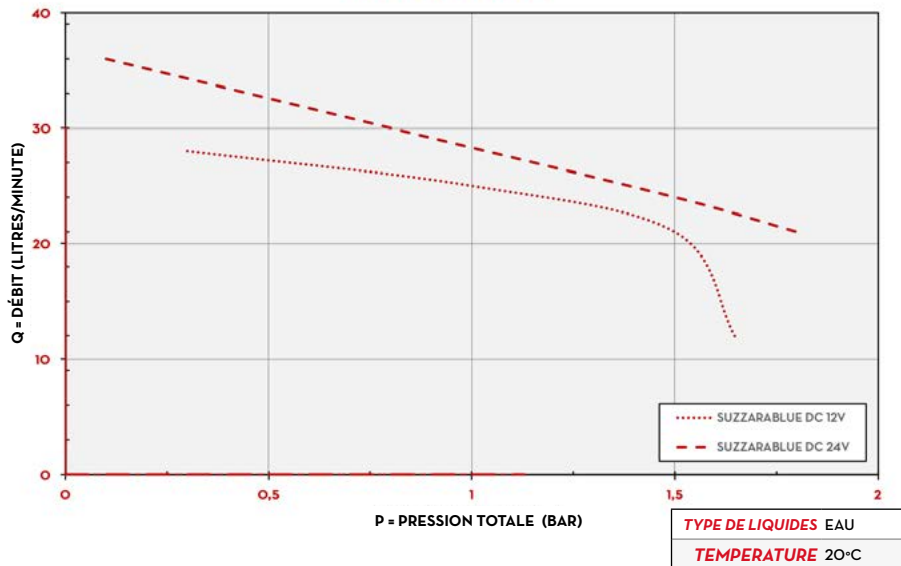

CONTENU DE L'EMBALLAGE

- POMPE SUZZARBLUE DC
- COLLIERS
- MANUEL D'INSTRUCTIONS

DÉTAILS



INTERRUPTEUR ON/OFF



COLLIERS

DIMENSIONS

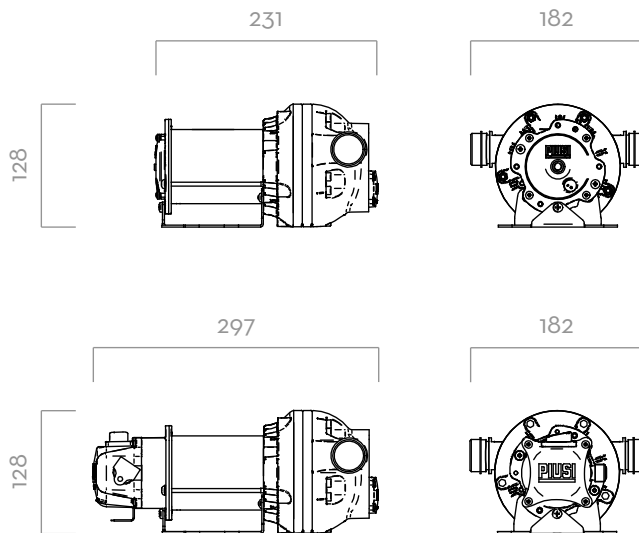

Dimensions exprimées en millimètres

MATÉRIAUX

- CORPS: POLIPROPYLENE
- MEMBRANE: POLIPROPYLENE

DONNÉES TECHNIQUES

CODE	DESCRIPTION	TYPE DE LIQUIDES	DÉBIT		TENSION				CÂBLE	ENTRÉE/SORTIE	ON/OFF
			L/MIN	GPM	AC V/HZ DC VOLT	RPM	PUISSANCE WATT	AMP. MAX.			
FOO204080	SUZZARBLUE DC PUMP 12V		35	9,2	12	2800	260	22	OUI	3/4"	OUI
FOO204090	SUZZARBLUE DC PUMP 24V		35	9,2	24	2800	310	13	OUI	3/4"	OUI