



CAR FILLING



FUEL MANAGEMENT SYSTEMS



KITS



PUMPS



METERS



METERED NOZZLES

SUZZARABLU PUMP DC

FEATURES

- **READY TO USE**
- **MULTI-PURPOSE PUMP**
- **SELF PRIMING**
- **BUILT-IN BYPASS VALVE**

The PIUSI SUZZARABLU PUMP DC is an electric DC diaphragm pump suitable for transferring AdBlue®. This self-priming pump is equipped with a built-in pressure by-pass.

PERFORMANCE

UP TO

35 L/MIN

FLOW RATE

20 MIN

DUTY CYCLE



SUZZARABLU PUMP DC



PACKAGING

CODE	WEIGHT		PACKAGING		N. BOXES/EUROPALLET	
	KG	LBS	MM	PCS/BOX		
FO0204080	3,6	7,9	350X180X280	1	60	84
FO0204090	3,6	7,9	350X180X280	1	60	84



NOZZLES



FILTRATION



TANK MONITORING



HOSE REEL



ACCESSORIES



MERCHANDISE



AIR



ANTIFREEZE



AdBlue®



BIODIESEL



DIESEL



FOOD



GASOLINE



GREASE



KEROSENE



OIL



WATER



WINDSCREEN

CHART

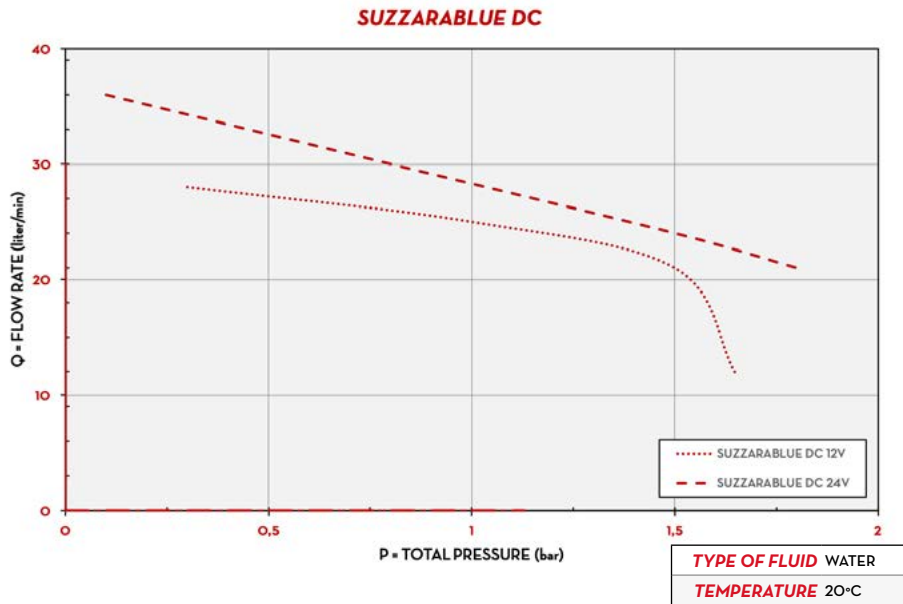

IN THE BOX

- SUZZARABLU PUMP DC
- CLAMPS
- INSTRUCTION MANUAL

DETAILS



DIMENSIONS

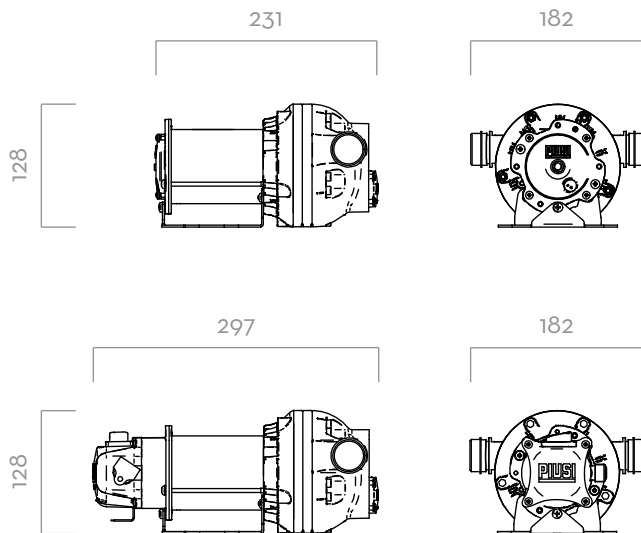

Dimensions expressed in millimeters

MATERIALS

- BODY: POLIPROPYLENE
- DIAPHRAGM: POLIPROPYLENE

TECHNICAL DATA

CODE	DESCRIPTION	FLUIDS TYPE	FLOW RATE		VOLTAGE				CABLES	INLET-OUTLET	ON/OFF
			L/MIN	GPM	AC V/HZ DC VOLT	RPM	POWER WATT	AMP. MAX.			
FO0204080	SUZZARABLU DC PUMP 12V		35	9,2	12	2600	260	22	YES	3/4"	YES
FO0204090	SUZZARABLU DC PUMP 24V		35	9,2	24	2600	310	10	YES	3/4"	YES