



FUEL MANAGEMENT SYSTEMS



DISPENSERS



KITS



POMPE



CONTALITRI



PISTOLE

# SELF SERVICE MC

## CARATTERISTICHE

- GESTIONE MULTIUTENTE
- FILTRO WATER CAPTOR
- ATTREZZATURA COMPATTA
- DESIGN COMPATTO
- COMPATIBILE CON IL SOFTWARE SSM AGILIS
- IP55

PIUSI SELF SERVICE MC è un dispositivo completo adatto a tutte le esigenze di erogazione del diesel. Con struttura robusta, questo dispenser è dotato di pompa a palette ad elevata portata, bypass incorporato, pistola automatica, filtro water captor e pannello elettronico in grado di gestire fino a 250 utenti e 255 transazioni.

### PERFORMANCE

FINO A

**90 L/MIN**

PORTATA

FUNZIONAMENTO

**AC**  
CONTINUO

POTENZA

**± 0,5%**

PRECISIONE

FINO A

**250**

UTENTI

Aggiorna il Tuo sistema MC a B.Smart con il KIT UPGRADE 1.0/2018.



ELECTRONIC METER INTEGRATED



SELF SERVICE MC



### PACKAGING

CODICE	PESO		PACKAGING			N. BOX / EUROPALET	
	KG	LBS	MM	INCH	PCS/BOX	✕	

#### COLUMN VERSION

FO073801E	67	148	1478X488X400	-	1	6	4
FO074101E	75	165	1478X488X400	-	1	6	4

#### TANK VERSION

FO0738BOE	57	126	1080X488X400	-	1	6	4
FO0741BOE	65	143	1080X488X400	-	1	6	4



FILTRAZIONE



MONITORAGGIO FLUIDI



ARROTOLATORI



ACCESSORI



MERCHANDISE

**PIUSI**

HS

ANY BIODIESEL

A

ARIA

A

ANTIGELO

Ad

AdBlue®

B

BODIESEL

D

DIESEL

F

ALIMENTI

G

BENZINA

G

GRASSO

K

KEROSENE

O

OLIO

W

ACQUA

W

LAVAVETRI

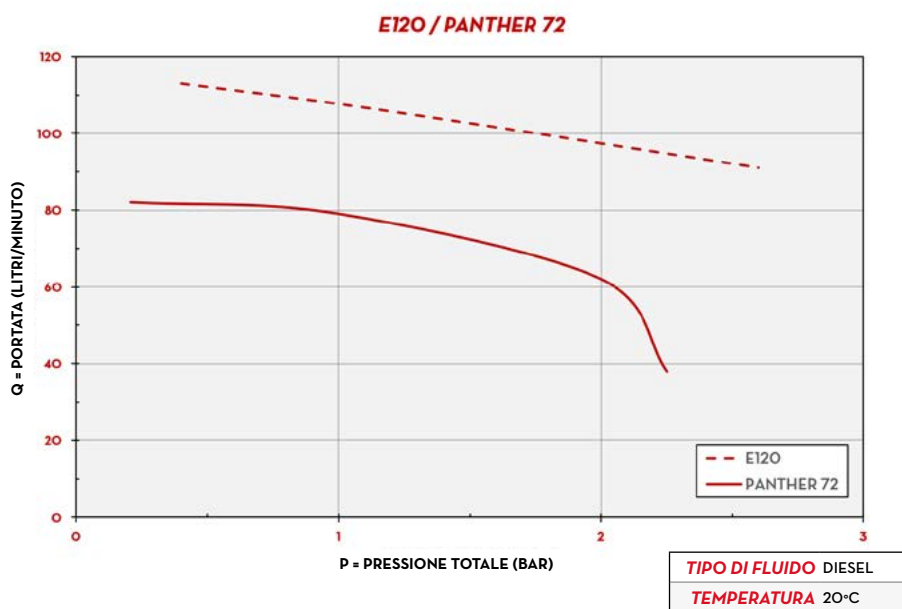
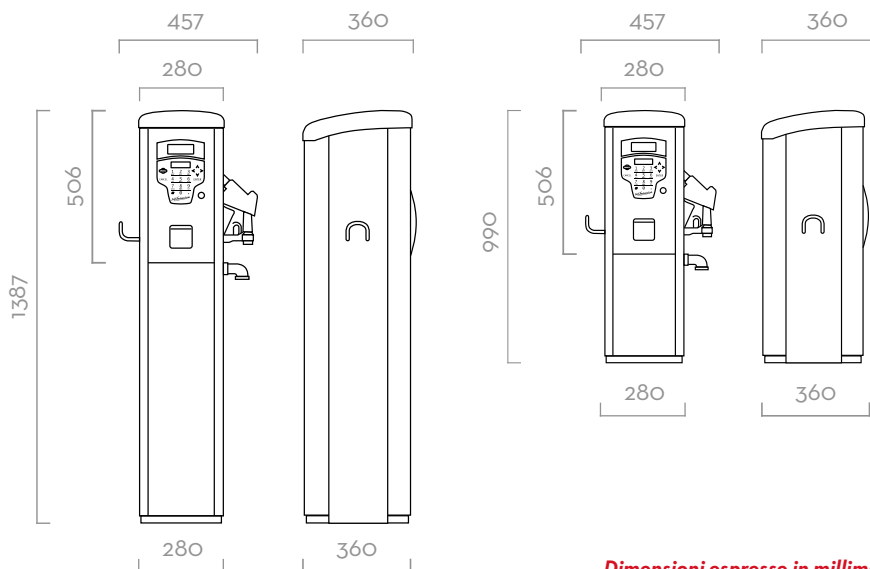
**GRAFICO****DIMENSIONI****DENTRO LA SCATOLA**

- DISPENSER SELF SERVICE MC
- TUBO DI MANDATA
- PISTOLA AUTOMATICA
- MANUALE ISTRUZIONI

**DETTAGLI**

VERSIONE SERBATOIO DISPONIBILE



FILTRO WATER CAPTOR



CHIAVE UTENTE (non inclusa)



SSM AGILIS SOFTWARE

**MATERIALI**

- **POMPE:**  
PANTHER 72 / E120
- **CONTALITRI:**  
K600/3
- **PISTOLA:**  
PISTOLA AUTOM.
- **FILTRO:**  
WATER CAPTOR

**DATI TECNICI**

CODICE	DESCRIZIONE	TIPO DI FLUIDO	PORTATA		VOLTAGGIO			PUMP	METER	NOZZLE	FILTER		INGRESSO	LUNGH. TUBO	PC
			L/MIN	GPM	AC V./HZ DC VOLT	POTENZA WATT	AMP. MAX.				H2O FILTER	CAPACITÀ FILTRANTE			

**COLUMN VERSIONS**

FO073801E	SELF SERVICE 70 MC 230V/50HZ AGILIS	D	70	18	230/50	800	3.9	PANTH 72	K600	A80	SI	30µ	1" 1/2	4	SI
FO074101E	SELF SERVICE 100 MC 230V/50HZ AGILIS	D	90	24	230/50	1100	5.5	E 120	K600	A120	SI	30µ	1" 1/2	4	SI

**TANK VERSIONS**

FO0738BOE	SELF SERVICE TANK 70MC 230V AGILIS	D	70	18	230/50	800	3.9	PANTH 72	K600	A80	NO	-	1" 1/2	4	SI
FO0741BOE	SELF SERVICE TANK100MC 230V AGILIS	D	90	24	230/50	1100	5.5	E 120	K600	A120	NO	-	1" 1/2	4	SI

SU RICHIESTA È DISPONIBILE CON DIVERSE TENSIONI E FREQUENZA 60 HZ