



FUEL MANAGEMENT SYSTEMS



DISPENSERS



KITS



PUMPS



METERS



NOZZLES

# SELF SERVICE MC

## FEATURES

- MULTI-USER MANAGEMENT
- WATER CAPTOR FILTER
- ALL-IN-ONE EQUIPMENT
- COMPACT DESIGN
- COMPATIBLE WITH SSM AGILIS SOFTWARE
- IP55

The PIUSI SELF SERVICE MC is a complete device suitable to fit all diesel dispensing needs. With its sturdy structure, this dispenser is equipped with a high capacity vane pump, built-in bypass, automatic nozzle, water captor filter and electronic panel able to manage up to 80 users and 255 transactions.

### PERFORMANCE

UP TO <b>90 L/MIN</b>	<b>AC</b> CONTINUOUS DUTY
FLOW RATE	POWER
<b>± 0,5%</b>	UP TO <b>250</b>
ACCURACY	USERS

Upgrade your MC hardware to B.SMART with KIT UPGRADE 1.0/2018.



ELECTRONIC METER INTEGRATED



SELF SERVICE MC



### PACKAGING

CODE	WEIGHT		PACKAGING			N. BOXES / EUROPALLET	
	KG	LBS	MM	INCH	PCS/BOX	✕	
<b>COLUMN VERSION</b>							
FO073801E	67	148	1478X488X400	-	1	6	4
FO074101E	75	165	1478X488X400	-	1	6	4
<b>TANK VERSION</b>							
FO0738BOE	57	126	1080X488X400	-	1	6	4
FO0741BOE	65	143	1080X488X400	-	1	6	4



FILTRATION



TANK MONITORING



HOSE REEL



ACCESSORIES



MERCHANDISE

# PIUSI



ANY BIODIESEL



AIR



ANTIFREEZE



AdBlue®



BIODIESEL



DIESEL



FOOD



GASOLINE



GREASE



KEROSENE



OIL



WATER



WINDSCREEN

## CHART

## IN THE BOX

- SELF SERVICE MC DISPENSER
- DELIVERY HOSE
- AUTOMATIC NOZZLE
- INSTRUCTION MANUAL

## DETAILS



TANK VERSION AVAILABLE



WATER CAPTOR FILTER



DRIVER KEY (not included)



SSM AGILIS SOFTWARE

## MATERIALS

- PUMPS:  
PANTHER 72 / E120
- METER:  
K600/3
- NOZZLE:  
AUTOMATIC NOZZLE
- FILTER:  
WATER CAPTOR

### E120 / PANTHER 72

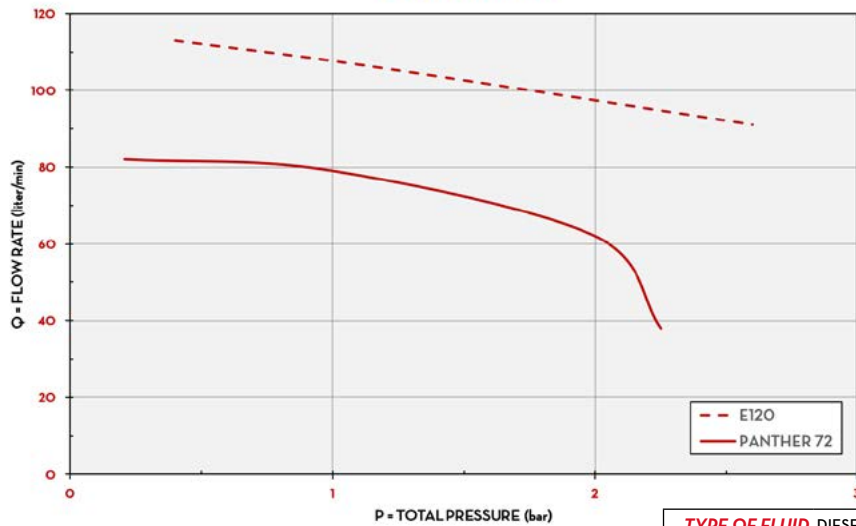

TYPE OF FLUID DIESEL  
TEMPERATURE 20°C

## DIMENSIONS

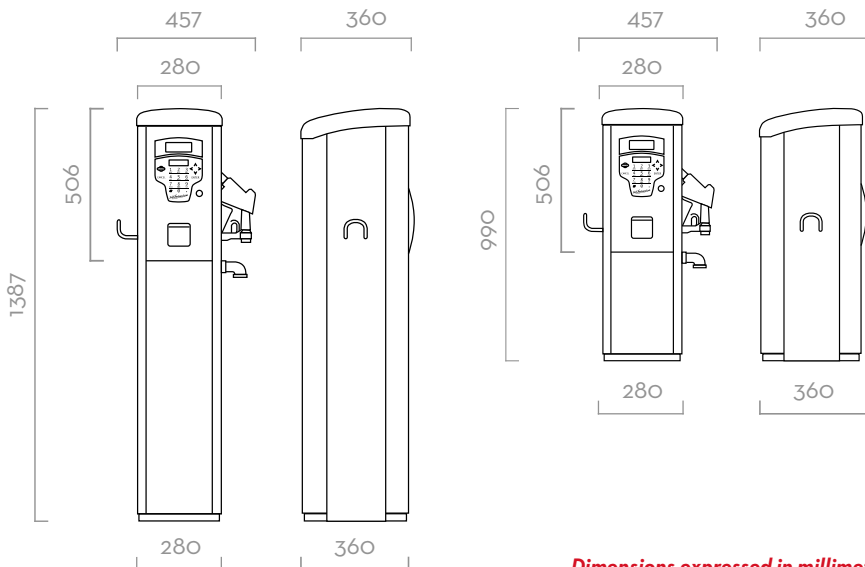

Dimensions expressed in millimeters

## TECHNICAL DATA

CODE	DESCRIPTION	FLUIDS TYPE	FLOW RATE		VOLTAGE			PUMP	METER	NOZZLE	FILTER		INLET	HOSE LENGTH	PC
			L/MIN	GPM	AC V/HZ	DC VOLT	POWER WATT				AMP. MAX.	H2O FILTER			

### COLUMN VERSIONS

FO073801E	SELF SERVICE 70 MC 230V/50HZ AGILIS	D	70	18	230/50	800	3.9	PANTH 72	K600	A80	SI	30µ	1" 1/2	4	SI
FO074101E	SELF SERVICE 100 MC 230V/50HZ AGILIS	D	90	24	230/50	1100	5.5	E 120	K600	A120	SI	30µ	1" 1/2	4	SI

### TANK VERSIONS

FO0738BOE	SELF SERVICE TANK 70MC 230V AGILIS	D	70	18	230/50	800	3,9	PANTH 72	K600	A80	NO	-	1" 1/2	4	SI
FO0741BOE	SELF SERVICE TANK100MC 230V AGILIS	D	90	24	230/50	1100	5,5	E 120	K600	A120	NO	-	1" 1/2	4	SI

UPON REQUEST IT IS AVAILABLE WITH DIFFERENT VOLTAGES AND 60 HZ FREQUENCY