



# CUBE MC

## CARACTÉRISTIQUES

- GESTION DE PLUSIEURS UTILISATEURS
- ÉQUIPEMENT TOUT-EN-UN
- DESIGN COMPACT
- COMPATIBLE AVEC LE SOFTWARE SSM 2018
- FILTRE D'ASPIRATION
- IP55

CUBE MC de PIUSI est la version mise à jour du groupe distributeur CUBE connu dans le monde entier. Il est équipé d'un panneau électronique permettant de gérer jusqu'à 120 utilisateurs et 255 transactions. Sa conception robuste inclut une pompe à ailettes à amorçage automatique, une dérivation intégrée, un pistolet de distribution automatique et un support de pistolet intégré avec levier de pompe marche/arrêt.

### PERFORMANCES

JUSQU'À

**70 L/MIN**

DÉBIT

**AC/DC**

TENSION

**± 0,5%**

PRÉCISION

JUSQU'À

**120**

UTILISATEURS



CUBE 70 MC



CUBE 70 MC AVEC PIEDESTAL (OPTIONEL)

### PACKAGING

CODE	POIDS		PACKAGING			N. BOX / EUROPALLET	
	KG	LBS	MM	INCH	PCS/BOÎTE	✕	🚚
FO059400D	25	55	400X400X460	-	1	12	24
FO059413C	25	55	400X400X460	-	1	12	24
FO059414C	25	55	400X400X460	-	1	12	24
FO059415C	25	55	400X400X460	-	1	12	24
FO059422A	25	55	400X400X460	-	1	12	24



FILTRAGE



SURVEILLANCE DES LIQUIDES



ENROULEUR



ACCESSOIRES



MERCHANDISE



AIR



ANTIGEL



AdBlue®



BIODIESEL



DIESEL



ALIMENTATION



ESSENCE



GRAISSE



KÉROSÈNE



HUILE



EAU



LAVE-GLACE

## GRAPHIQUE

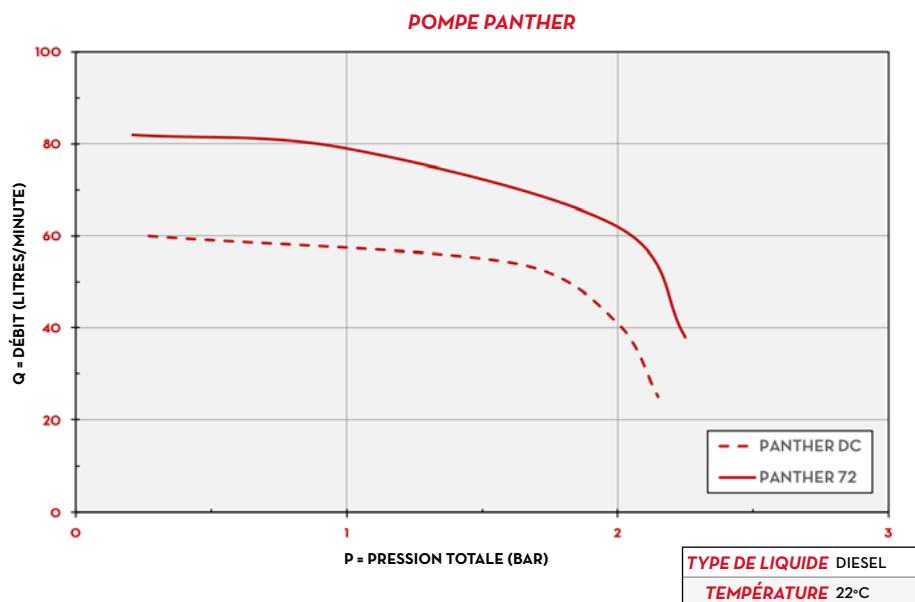

## DIMENSIONS

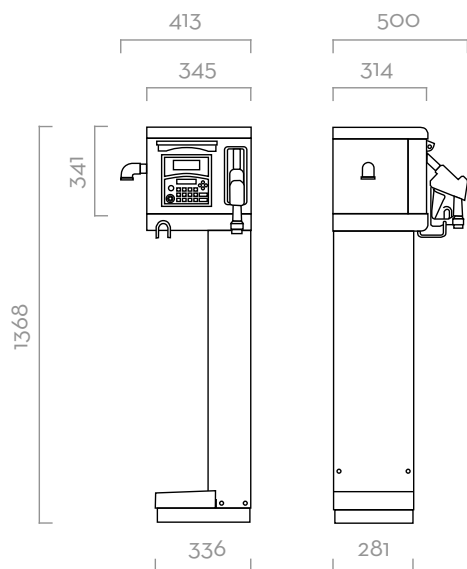

Dimensions exprimées en millimètres

## CONTENU DE L'EMBALLAGE

- DISTRIBUTEUR CUBE MC
- PISTOLET AUTOMATIQUE
- TUYAU DE DISTRIBUTION
- MANUEL D'INSTRUCTIONS

## DÉTAILS



## COMPOSANTS

- **POMPES:**  
PANTHER AC PAG. 102  
PANTHER DC PAG. 114
- **COMPTEUR:**  
K600/3 PAG. 134
- **PISTOLET:**  
PISTOLET AUTOMATIQUE PAG. 158

## DONNÉES TECHNIQUES

CODE	DESCRIPTION	TYPE DE LIQUIDES	DÉBIT		TENSION			POMPE	COMP-TEUR	PISTOLET	FILTRE	ENTRÉE	TUYAU		PC		UTILISA-TEURS
			L/MIN	GPM	AC V/HZ	DC VOLT	PUISSANCE WATT						AMP. MAX.	TYPE	LONG.	Ø	
FO059400D	CUBE 70 MC	D	70	18	230/50	900	4,2	PANTH 72	K600	A60	NON	1"	4M	1"	OUI	50	
FO059413C	CUBE 70 MC DC 12V	D	56	15	12	300	35	PANTH DC	K600	A60	NON	1"	4M	1"	OUI	50	
FO059414C	CUBE 70 MC DC 24V	D	70	18	24	420	25	PANTH DC	K600	A60	NON	1"	4M	1"	OUI	50	
FO059415C	CUBE 70 MC 120 UT	D	70	18	230/50	550	3,3	PANTH 72	K600	A60	NON	1"	4M	1"	OUI	120	
FO059422A	CUBE 70 MC 12V 120 UT	D	56	15	12	300	35	PANTH DC	K600	A60	NON	1"	4M	1"	OUI	120	

SUR DEMANDE, PRODUIT DISPONIBLE AVEC PLUSIEURS TENSIONS ET FRÉQUENCE DE 60 HZ.

# CUBE MC