



KRAFTSTOFFMANAGEMENT-SYSTEM



ABGABEEINHEITEN



KITS



PUMPEN



ZÄHLER



ZAPFVENTIL

CUBE MC

MERKMALE

- VERWALTUNG MEHRERER BENUTZER
- ALLES IN EINER ANLAGE
- KOMPAKT KONSTRUIERT
- MIT SOFTWARE SSM 2018 KOMPATIBEL
- ANSAUGFILTER
- IP55

Die PIUSI CUBE MC ist die aktualisierte Ausführung der weltbekannten CUBE-Abgabeeinheit mit elektronischem Bedienfeld, das bis zu 120 Benutzer und 255 Transaktionen verwalten kann. Die robuste Konstruktion umfasst eine selbstansaugende Drehschieberpumpe, einen integrierten Bypass, Automatik-Zapfventil und einen integrierten Zapfventilhalter mit Start/Stop-Pumpenhebel.

LEISTUNGSPARAMETER

BIS ZU

70 L/MIN

VOLUMENSTROM

AC/DC

SPANNUNG

STROMVERSORGUNG

± 0,5%

GENAUIGKEIT

BIS ZU

120

NUTZER



CUBE 70 MC



CUBE 70 MC MIT SOCKEL (OPTIONAL)

VERPACKUNG

CODE	GEWICHT		VERPACKUNG			N. BOX / EUROPALLET	
	KG	LBS	MM	ZOLL	STCK./KARTON	✕	🚚
FO059400D	25	55	400X400X460	-	1	12	24
FO059413C	25	55	400X400X460	-	1	12	24
FO059414C	25	55	400X400X460	-	1	12	24
FO059415C	25	55	400X400X460	-	1	12	24
FO059422A	25	55	400X400X460	-	1	12	24



FILTERUNG



TANKÜBERWACHUNG



SCHLAUCHAUFROLLER



ZUBEHÖR



MERCHANDISE



LUFT



FROSTSCHUTZ



AdBlue®



BIODIESEL



DIESEL



LEBENS M.



BENZIN



SCHMIERM.



KEROSIN



ÖL



WASSER



WISCHERFLÜSS.

KENNLINIEN

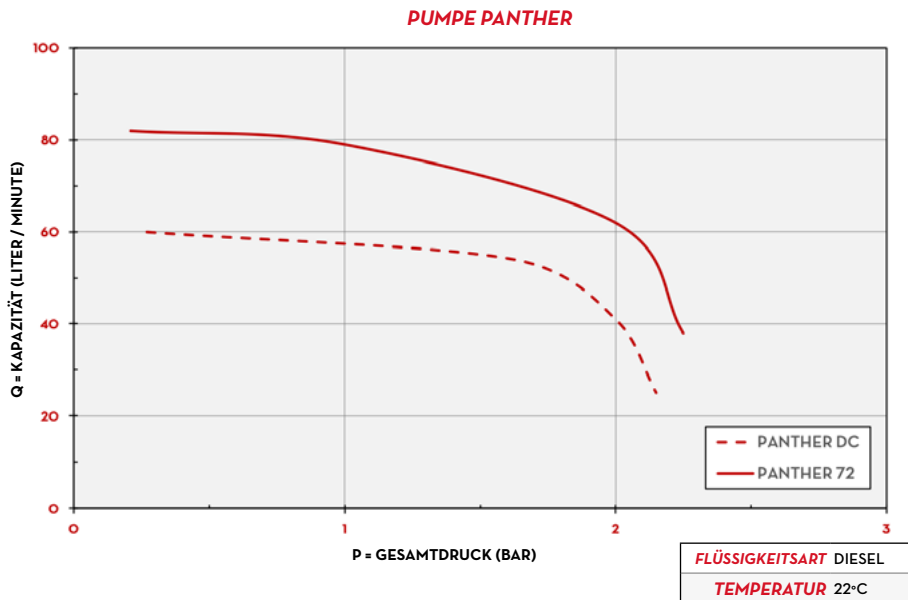

ABMESSUNGEN

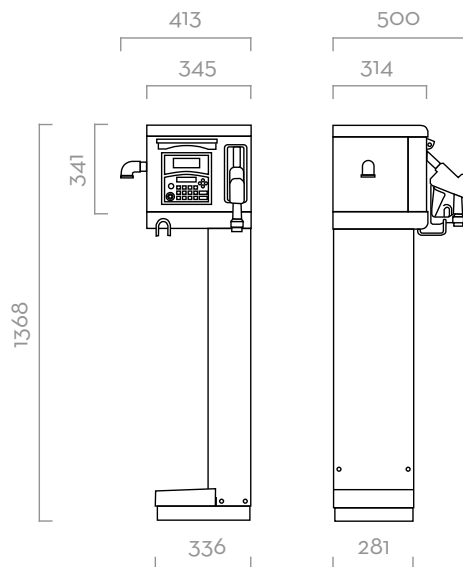

Maße in Millimetern

LIEFERUMFANG

- CUBE MC-EINHEIT
- AUTOMATIK-ZAPFVENTIL
- VERSORGUNGSSCHLAUCH
- BEDIENUNGSANLEITUNG

EINZELHEITEN



MATERIALIEN

- **PUMPEN:**
PANTHER AC S. 102
PANTHER DC S. 114
- **ZÄHLER:**
K600/3 S. 134
- **ZAPFVENTIL:**
AUTOMATIK-ZAPFVENTIL S. 158

TECHNISCHE DATEN

CODE	BESCHREIBUNG	FLÜSSIGKEITSART	VOLUMENSTROM		SPANNUNG			PUMPE	ZÄHLER	ZAPFVENTIL	FILTER	EINLASS	SCHLAUCH		PC		NUTZER
			L/MIN	GPM	AC V/ HZ DC VOLT	STROMWATT	AMP. MAX.						TYP	TYP	H2O FILTER	BSP	
FO059400D	CUBE 70 MC	D	70	18	230/50	900	4,2	PANTH 72	K600	A60	NEIN	1"	4M	1"	JA	50	
FO059413C	CUBE 70 MC DC 12V	D	56	15	12	300	35	PANTH DC	K600	A60	NEIN	1"	4M	1"	JA	50	
FO059414C	CUBE 70 MC DC 24V	D	70	18	24	420	25	PANTH DC	K600	A60	NEIN	1"	4M	1"	JA	50	
FO059415C	CUBE 70 MC 120 UT	D	70	18	230/50	550	3,3	PANTH 72	K600	A60	NEIN	1"	4M	1"	JA	120	
FO059422A	CUBE 70 MC 12V 120 UT	D	56	15	12	300	35	PANTH DC	K600	A60	NEIN	1"	4M	1"	JA	120	

AUF ANFRAGE AUCH MIT UNTERSCHIEDLICHER SPANNUNG UND 60 HZ FREQUENZ LIEFERBAR.

CUBE MC