



FUEL MANAGEMENT
SYSTEMS



DISPENSERS



KITS



POMPE



CONTALITRI



PISTOLE

ST 200 AC

CARATTERISTICHE

- ROBUSTO TELAIO METALLICO
- PRONTO ALL'USO
- FACILE DA SPOSTARE
- CONDIZIONI DI LAVORO GRAVOSE

PIUSI ST 200 AC è un dispenser che consente un'elevata portata di carburante grazie alle due elettropompe rotative a palette autoadescanti E120 integrate. Dotato di valvola di by-pass e guarnizione ad elevata affidabilità, il dispenser funziona anche a basse temperature di esercizio e in ogni condizione di lavoro. Il contaltri meccanico a ingranaggi ovali garantisce una grande precisione (disponibile su richiesta). Disponibile anche in versione carrellata con manico (su richiesta) per spostamenti più facili.

PERFORMANCE

FINO A

200 L/MIN

PORTATA

FUNZIONAMENTO

AC
CONTINUO

POTENZA



ST 200 AC



KIT TRASPORTABILE: VERSIONE CON RUOTE E MANIGLIA

PACKAGING

CODICE	PESO		PACKAGING		
	KG	LBS	MM	INCH	PCS/BOX
FO0315000	46	101	587X395X420	23,1X15,6X16,5	1
F16860000	-	-	-	-	-



FILTRAZIONE



MONITORAGGIO FLUIDI



ARROTATORI



ACCESSORI



MERCHANDISE



ARIA



ANTIGELO



AdBlue®



BIODIESEL



DIESEL



ALIMENTI



BENZINA



GRASSO



KEROSENE



OLIO



ACQUA



LAVAVETRI

GRAFICO

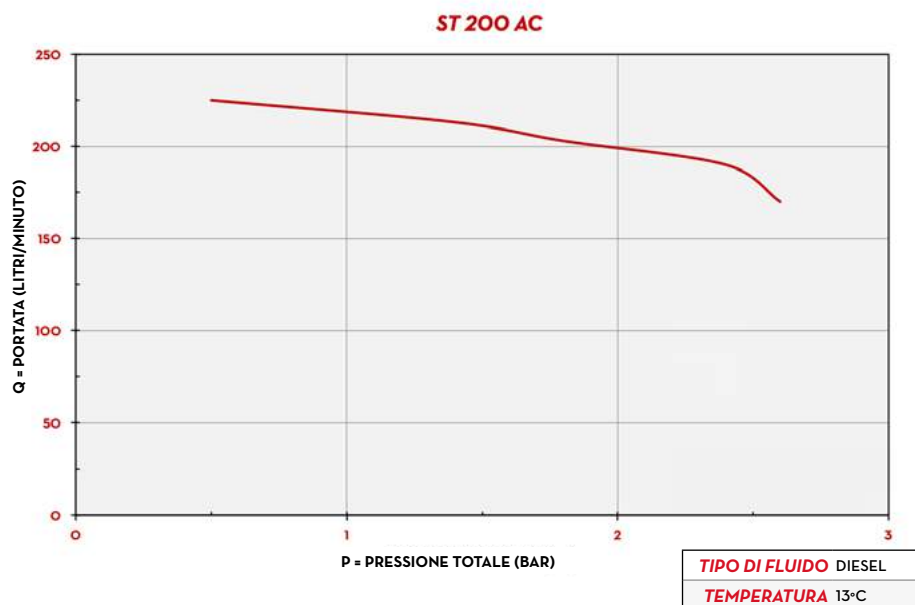

DENTRO LA SCATOLA

- GRUPPO ST 200 AC
- MANUALE ISTRUZIONI

DETTAGLI



SELETTORE ON/OFF

DIMENSIONI

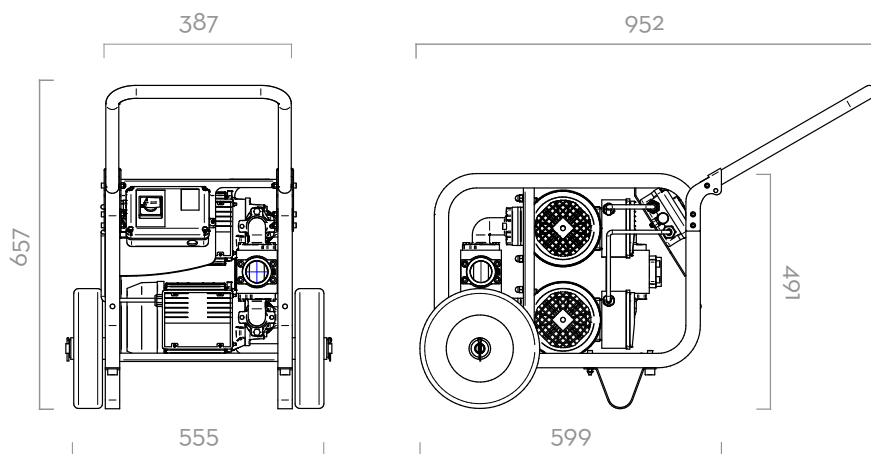

Dimensioni espresse in millimetri

MATERIALI

- CORPO: GHISA
- ROTORE: ACCIAIO SINTERIZZATO
- PALETTE: RESINA ACETALICA
- GUARNIZIONE: VITON
- ALBERO: ACCIAIO

DATI TECNICI

CODICE	DESCRIZIONE	TIPO DI FLUIDO	PORTATA		VOLTAGGIO			PUMP		PRESSIONE MAX	OUTLET
			L/MIN	GPM	AC V/HZ DC VOLT	POTENZA WATT	AMP. MAX.	TIPO	N°	BAR	BSP
FO0315000	ST 200 BASIC	D	200	52,7	230/50	2050	10	E 120	2	2,5	1" 1/2
FI6860000	HANDY KIT (MANIGLIA + WHEELS)	D	-	-	-	-	-	-	-	-	-

ST200 AC