

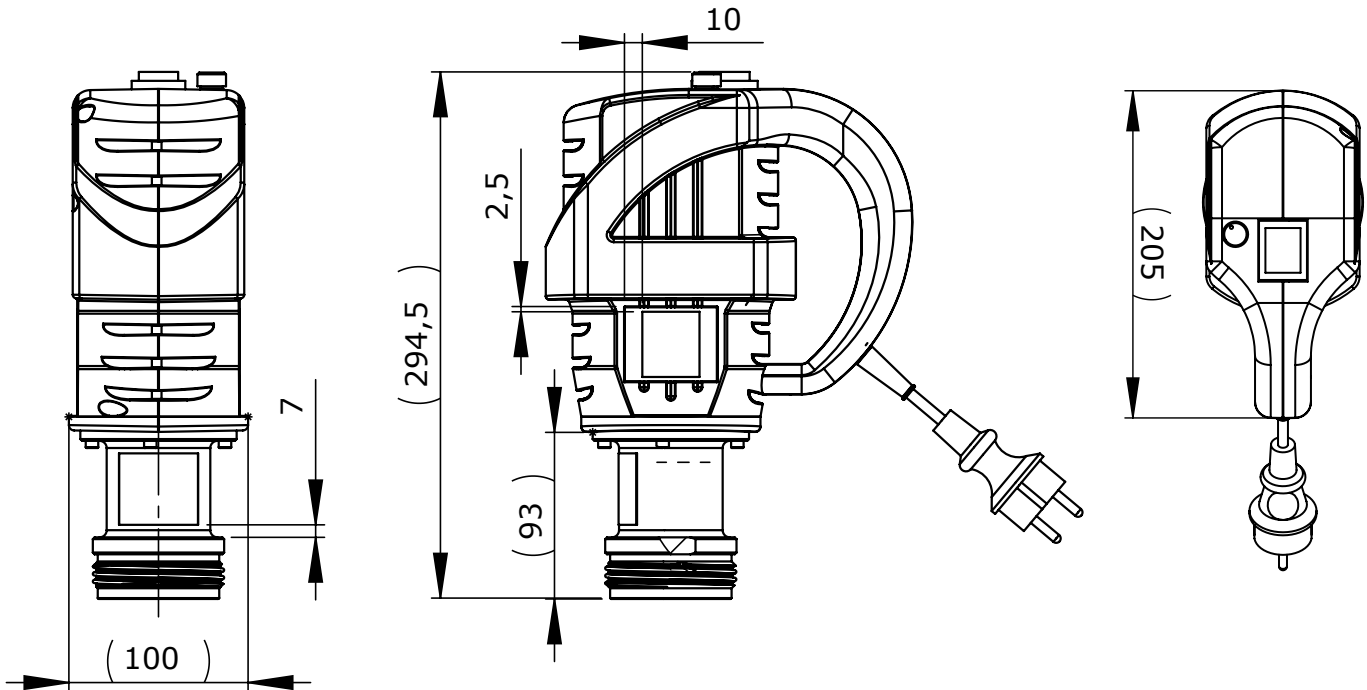

## Technical Specifications

Enclosure:	TEFC (IP54)
Voltage:	230V
Power Rating:	650 W
Phase:	1
Nominal Current:	3,5 A
Frequency:	50-60 Hz
Insulation Class:	Class I
Certification:	CE
Housing Material:	Thermoplastic Polyamid
Power Cord Length:	4,0 m
Power Cord Plug Type:	CEE 7/7
Noise Level:	75-83 dBa
Thermal Overload:	Yes
Variable Speed:	SPE-650V: 1.000-9.500 rpm
Fixed Speed:	SPE-650: 9.500 rpm
Weight:	3,3 kg



**WARNING:** Not suitable for pumping flammable or combustible liquids or use in a hazardous duty environment.

**Note:** Not recommended for use with the SP-700SR or 800SR Series pump.