



AUTOBETANKUNG



KRAFTSTOFFMANAGEMENT-SYSTEM



KITS



PUMPEN



ZÄHLER



ZAPFVENTILZÄHLER

# SUZZARABLUE 3 PRO

## MERKMALE

- **ROBUSTES DESIGN**
- **ZUVERLÄSSIG AUCH IN NICHT OPTIMALEN SITUATIONEN**
- **JEDERZEIT GARANTIERTE AUSGABEBEREITSCHAFT**
- **IMMER SAUBERES ADBLUE**
- **FÜR ALLE EINSATZBEDINGUNGEN UND ANWENDUNGEN GEEIGNET**
- **ERGONOMISCHE BEFESTIGUNG FÜR IBC-TANKS**
- **ZAHLREICHE KONFIGURATIONS-MÖGLICHKEITEN**
- **PIUSI ZÄHLER (SB325\_X METER/ K24)**

## LEISTUNGSPARAMETER

BIS ZU

**35 L/MIN**

VOLUMENSTROM

**AC/DC**

SPANNUNG

**6M**

ABGABESCHLAUCH

**20 MIN**

BETRIEBSZYKLUS

SUZZARABLUE 3 PRO ist die Spitze des PIUSI- Sortiments für den Transfer von AdBlue® aus einem IBC-Tank. Sie eignet sich für alle Arbeitsbedingungen und alle Nutzfahrzeuge. Die technischen Eigenschaften und die Leistungsmerkmale der Version SUZZARABLUE 3 BASIC werden mit der Präzision des Literzählers K24 für AdBlue® oder der Literzählerpistole SB325\_X METER ergänzt.



SUZZARABLUE 3 PRO



## VERPACKUNG

CODE	GEWICHT		VERPACKUNG		
	KG	LBS	MM	ZOLL	STCK./KARTON
FO0101580	14,5	32	480X390X310	19,3X15,4X12,2	1
FO0101440	14,5	32	480X390X310	19,3X15,4X12,2	1
FO0101420	14,5	32	480X390X310	19,3X15,4X12,2	1
FO0101430	14,5	32	480X390X310	19,3X15,4X12,2	1
FO010102A	14,5	32	480X390X310	19,3X15,4X12,2	1
FO010100A	14,5	32	480X390X310	19,3X15,4X12,2	1



ZAPFVENTILE



FILTERUNG



FLÜSSIGKEIT-SÜBERWACHUNG



SCHLAUCHAUFROLLER



ZUBEHÖR



MERCHANDISE



LUFT



FROSTSCHUTZ



AdBlue®



BIODIESEL



DIESEL



LEBENS.M.



BENZIN



SCHMIERM.



KEROSIN



ÖL



WASSER



WISCHERFLÜSS.

## KENNLINIEN

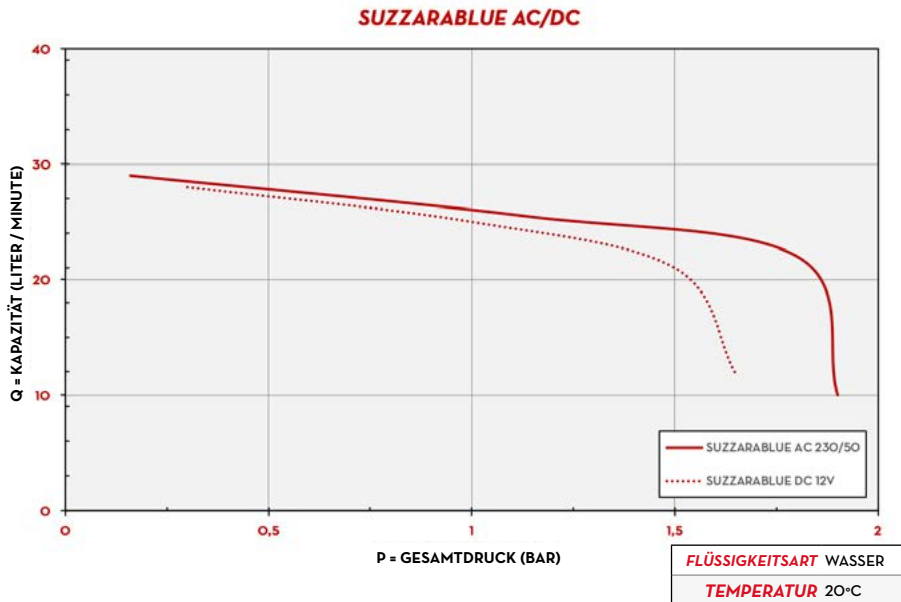

## ABMESSUNGEN

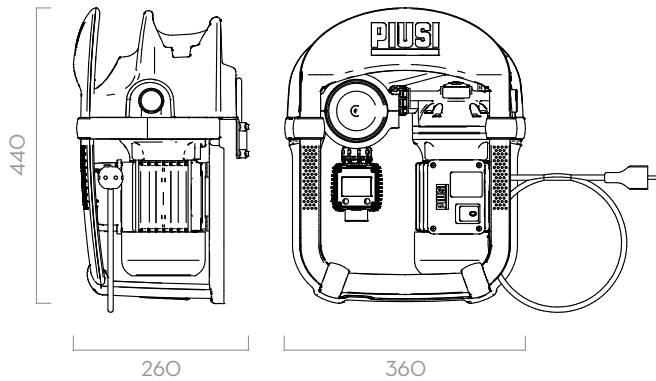

Maße in Millimetern

## LIEFERUMFANG

- SUZZARABLUE 3
- ANSAUG- & VERSORGUNGSSCHLAUCH
- MANUELLES/AUTOM. ZAPFVENTIL (AUF ANFRAGE)
- K24 ZÄHLER (AUF ANFRAGE)
- SEC-ANSCHLUSS (\*)
- 3D FILTER (AUF ANFRAGE)
- BEDIENUNGSANLEITUNG

## EINZELHEITEN



## KOMPONENTEN

- PUMPEN:  
SUZZARABLUE PUMP AC  
SUZZARABLUE PUMP DC
- ZAPFVENTILE:  
SB325\_X  
SUZZARABLUE A60  
SUZZARABLUE MANUAL NOZZLE
- FILTER:  
3D FILTER
- ZÄHLER:  
K24  
SB325\_X METER

## TECHNISCHE DATEN

CODE	BESCHREIBUNG	FLÜSSIGKEITS-ART	VOLUMEN-STROM		SPANNUNG LEISTUNG	ZÄHLER TYPE	ZAPFVENTILE TYPE	3D FILTER	IBC ANSAUGUNG	SCHLAUCH	
			L/MIN	GPM						SAUG. Ø 3/4	LIEFE- RUNG
FOO101580	SUZZ.BLUE3 PRO 230/50 K24/MAN/EXT	Ad W	35	9,3	12V	K24	MAN	NO	EXT	EXT	EXT
FOO101440	SUZZ.BLUE3 PRO 230/50 K24/A60	Ad W	35	9,3	230V 50HZ	K24	A60	NO	SEC	1,5 M Ø20	6 M Ø20
FOO101420	SUZZ.BLUE3 PRO 230/50 K24/SB325/EXT	Ad W	35	9,3	230V 50HZ	K24	SB325_X	NO	EXT	EXT	EXT
FOO101430	SUZZ.BLUE3 PRO 230/50 K24/SB325	Ad W	35	9,3	230V 50HZ	K24	SB325_X	NO	SEC	1,5 M Ø20	6 M Ø20
FOO10102A	SUZZ.BLUE3 PURE PRO 230/50 K24/SB325/EXT	Ad W	35	9,3	230V 50HZ	K24	SB325_X	JA	EXT	EXT	EXT
FOO10100A	SUZZ.BLUE3 PURE PRO 230/50 K24/SB325	Ad W	35	9,3	230V 50HZ	K24	SB325_X	JA	SEC	1,5 M Ø20	6 M Ø20

\* ANDERE IBC-ANSCHLÜSSE VERFÜGBAR: AF2, AXTERNAL SUCTION

\*\* ANDERE ZAPFVENTILE VERFÜGBAR: SB325\_X, SUZZARABLUE A 60