

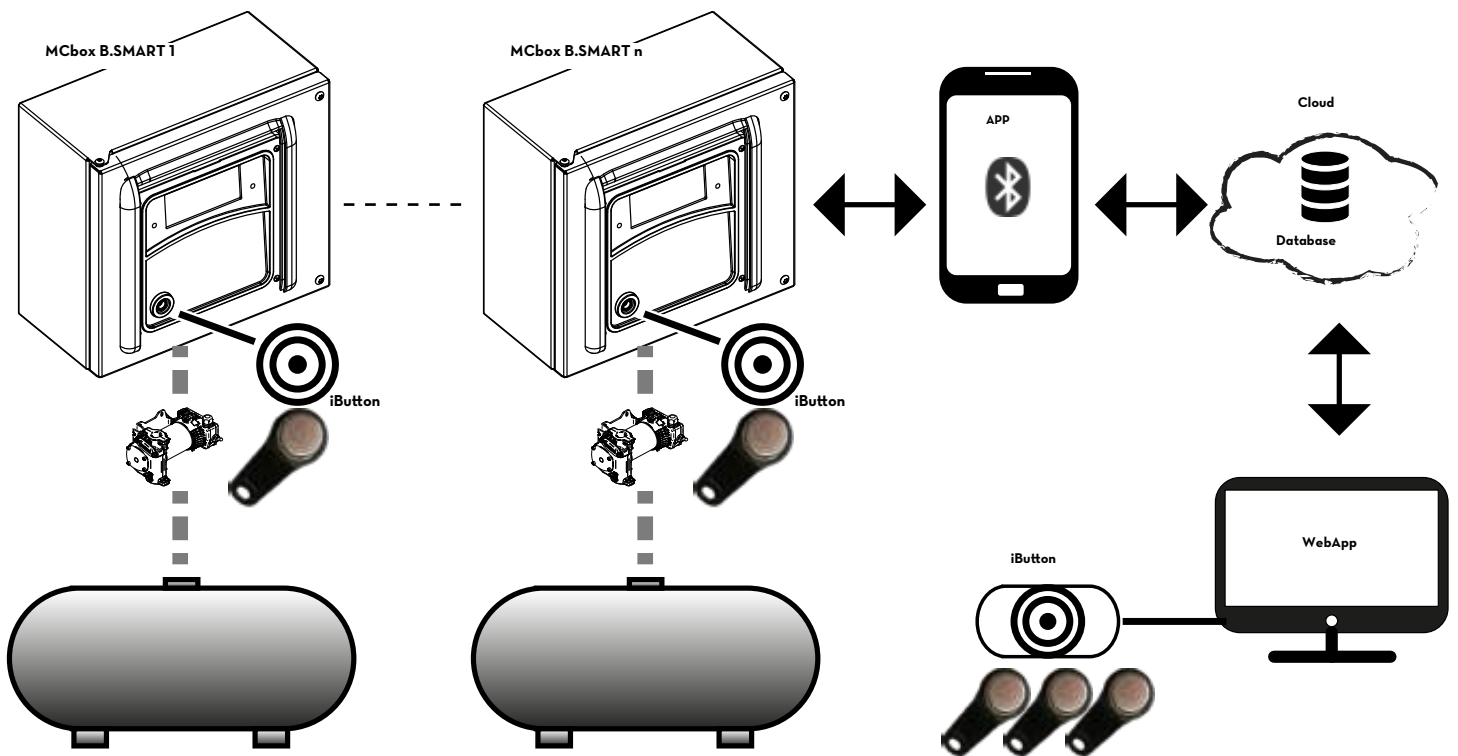

Level Indicator Update



As can be seen from the descriptive diagram, each controller can manage 1 pump. There are numerous system configurations when using one or more controller. An example of the basic system structure is provided showing the possibility to:

- Manage 1 motor output
- Monitor the level in 1 or 2 tanks, as needed, even when a tank is shared by pumps connected to different controllers.
- Manage multiple controllers simultaneously, within the same plant

For more specific details on modes of connection and communication between controllers, please refer to the manual found in the system management WebApp.

B.SMART BOX



OCIO 2.0 RS485

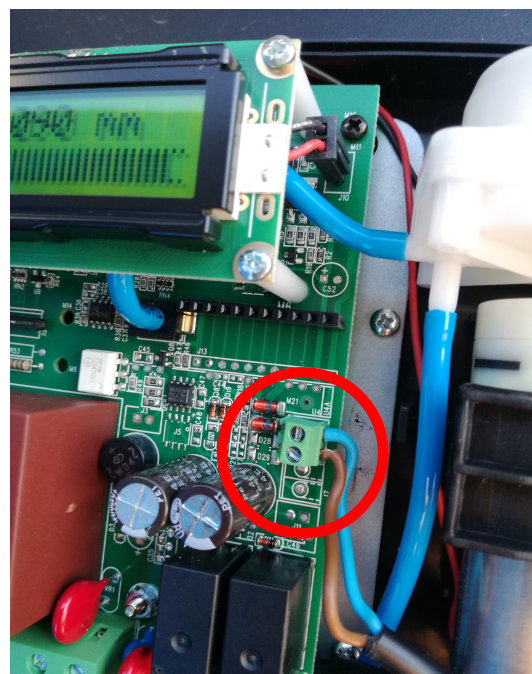

ELECTRICAL CONNECTIONS

Power supply INPUT 100/240 Vac depending on motor models - 50/60 Hz. The line must be disconnected by an electrical panel or a plug-socket assembly.

Connectors for: level 1 and 2 contact, pulser input, GND and 24 Vdc and 25 mA power supply output

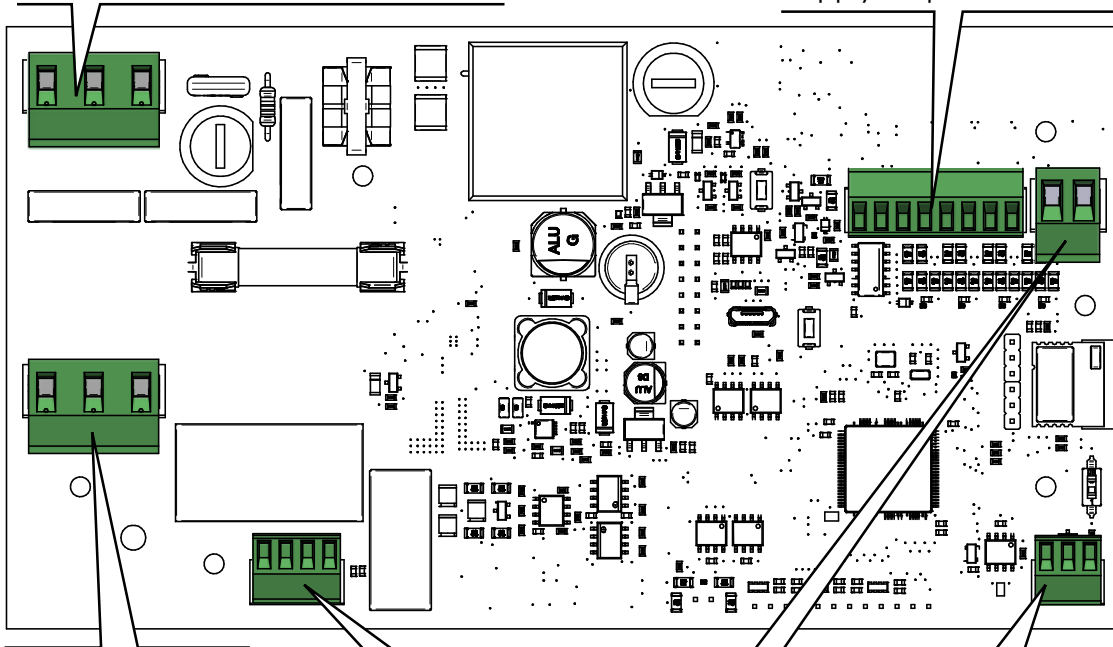

MOTOR OUTPUT
100-240 Vac
50/60 Hz
(output voltage and frequency same as input)

RS485 connector

Nozzle Contact (used on the Self Service model, optional on the MCBOX and not used on the CUBE model)

CANBUS connector

SIGNAL CONNECTOR

Output 24 V dc, pulser, level 1 and 2 contact.

Tighten the screws on the top of the 8-hole terminal for:

Level 1 contact, level 2 contact and pulser.

With reference to the level 1 contact and level 2 contact, it is necessary to underline that these are configurable contacts which can be used to connect:

- Level sensor 4-20mA
- Level sensor 0-10V
- Clean contact (switch not necessarily connected to the level sensors inside the tank)

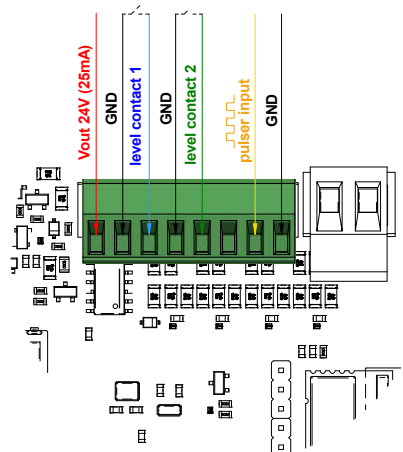

SERIAL CONNECTION

The B.Smart board has two RS485 serial communication channels. As well as the level contacts on the signals terminal board, it is possible to connect the OCIO detection system to the B.Smart board.

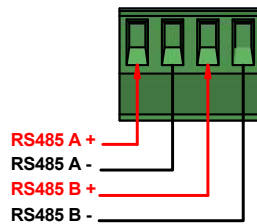

If using OCIO 2.0 connected with RS485 serial, DO NOT use the level 1 and level 2 contacts of the signal connector

CANBUS CONNECTION

The controllers can be connected to each other, via CANBUS connection. The figure shows the connector on each individual board and a small diagram showing the connection between x number of controllers.

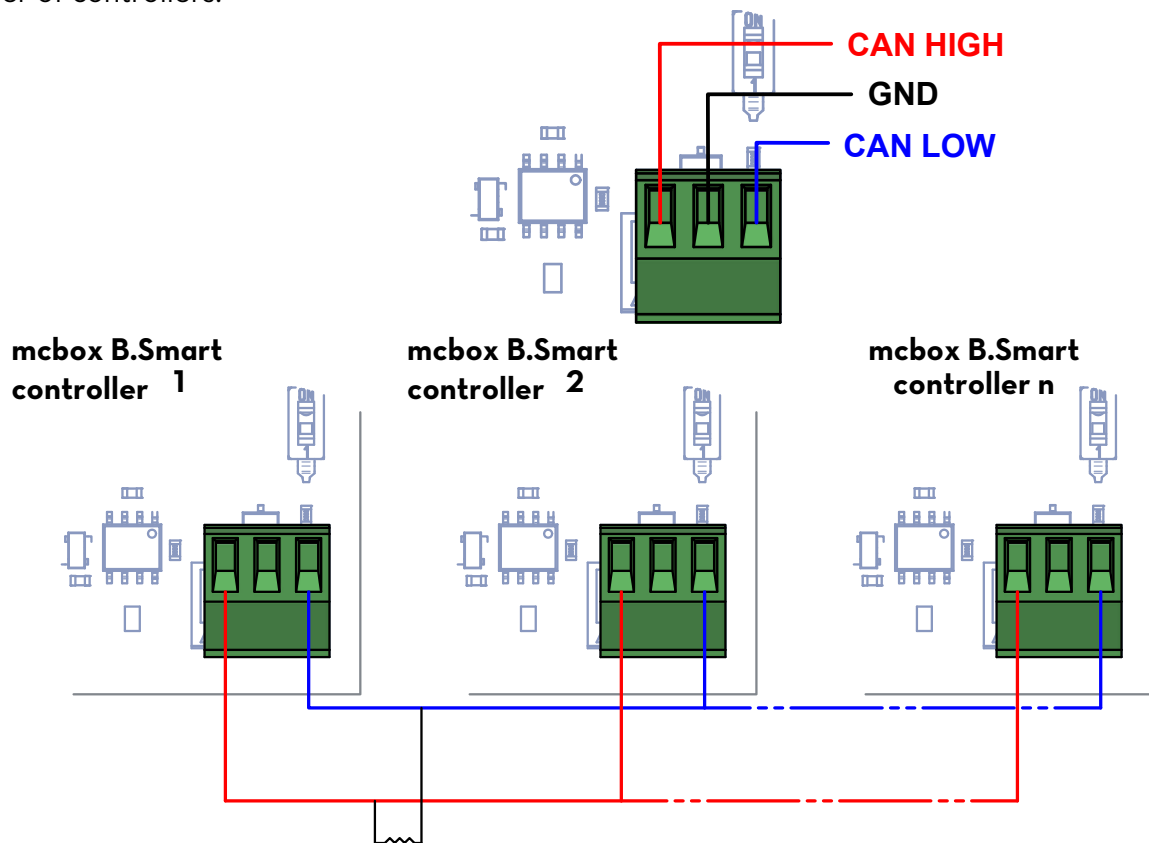

Insert the 120 ohm resistor provided between CAN HIGH - CAN LOW and connect the resistor output wires to the terminal boards, as shown in the figure.

CAUTION



The 120 ohm resistor must be inserted in the CANBUS line **ONCE ONLY**, as shown in the connection diagram.

NOTE



For the CANBUS connection, it is recommended to:

- Use a cable with a characteristic impedance of 120 ohms
- The length of the connection between the various MCBOX B.SMARTs must not exceed 100 m.

