



SYSTÈMES DE GESTION DU CARBURANT



DISTRIBUTEURS



KITS



POMPES



COMPTEURS



PISTOLETS

K700

CARACTÉRISTIQUES

- CONDITIONS DIFFICILES
- STRUCTURE SOLIDE
- PRESSION D'ÉCLATEMENT 30 BARS
- PAS DE BATTERIE NÉCESSAIRE
- FACILE À INSTALLER
- 2 SENS DE DÉBIT

Les débits moyens et élevés nécessitent un équipement de mesure spécifique capable d'adapter le débit avec précision. C'est le cas du débitmètre mécanique à engrenages ovales K700 de PIUSI: un équipement solide, fiable et facile à installer qui convient aux environnements les plus exigeants. Le compteur affiche le total partiel sur 4 chiffres et peut aller jusqu'à 9999 litres.

PERFORMANCES

40-220

L/MIN

DÉBIT

10 BAR

MAX
PRESSION

FONCTIONNEMENT

± 1,5%

PRÉCISION

0,3%

RÉPÉTABILITÉ



K700



PACKAGING

CODE	POIDS		PACKAGING			N. BOX / EUROPALLET	
	KG	LBS	MM	INCH	PCS/BOÎTE	✕	🚚
FO0540000	5,8	12,8	240X240X275	-	1	48	72
FO0540020	5,8	12,8	240X240X275	-	1	48	72
FO0540030	5,8	12,8	240X240X275	-	1	48	72
FO0540040	5,8	12,8	240X240X275	-	1	48	72



FILTRAGE



SURVEILLANCE
DES LIQUIDES



ENROULEUR



ACCESSOIRES



MERCHANDISE



AIR



ANTIGEL



AdBlue®



BIODIESEL



DIESEL



ALIMENTATION



ESSENCE



GRAISSE



KÉROSÈNE



HUILE



EAU



LAVE-GLACE

GRAPHIQUE

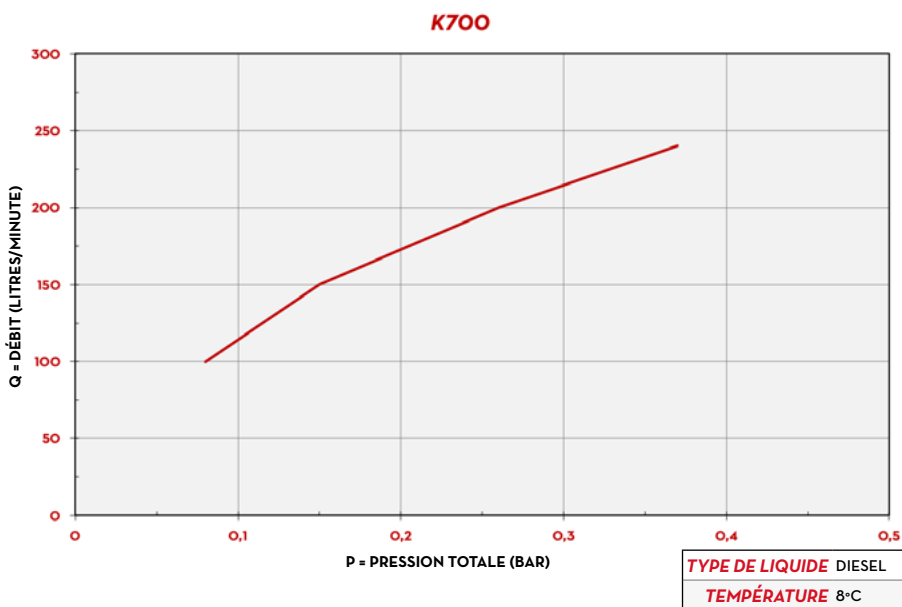

DIMENSIONS

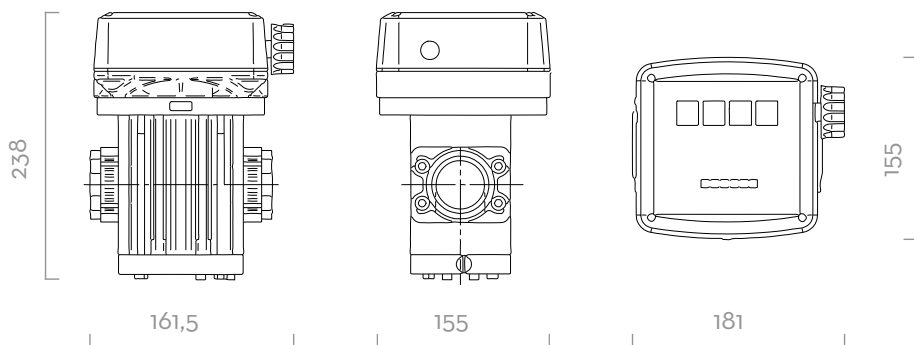

Dimensions exprimées en millimètres

CONTENU DE L'EMBALLAGE

- COMPTEUR K700
- MANUEL D'INSTRUCTIONS

DÉTAILS



MATÉRIAUX

- CORPS: ALUMINIUM
- ENGRENAGES: TECHNOPOLYMÈRE

DONNÉES TECHNIQUES

CODE	DESCRIPTION	TYPE DE LIQUIDES	SENS DE DÉBIT	DÉBIT		PRESSION		FILTRE D'ENTRÉE	ENTRÉE/SORTIE
				L/MIN	GPM	BAR	PSI		
FO0540000	K700 VER. A	D	◀	40 - 220	5 - 53	10	142	OUI	1" 1/2 BSP
FO0540020	K700 VER. B	D	▲	40 - 220	5 - 32	10	142	OUI	1" 1/2 BSP
FO0540030	K700 VER. C	D	▼	40 - 220	5 - 53	10	142	OUI	1" 1/2 BSP
FO0540040	K700 VER. D	D	▶	40 - 220	5 - 32	10	142	OUI	1" 1/2 BSP

K700