



FUEL MANAGEMENT SYSTEMS



DISPENSERS



KITS



PUMPS



METERS



NOZZLES

SELF SERVICE B.SMART

FEATURES

- FUEL MANAGEMENT SYSTEM B.SMART INTEGRATED
- NO SOFTWARE INSTALLATION REQUIRED
- SUITABLE FOR FLEETS OF ALL SIZES
- REAL TIME FEEDBACK FROM ANYWHERE
- BUILT-IN FILTER
- ALL-IN-ONE EQUIPMENT
- COMPACT DESIGN
- KIT UPGRADE 1.0/2018 AVAILABLE

Top quality diesel dispenser by PIUSI, combined with the innovative B.SMART fuel management system: this is the core of the new SELF SERVICE B.SMART. A complete device specifically engineered to fit all diesel transfer needs while performing all the features of a fuel management software in terms of monitoring, controlling and managing the consumption of fuel by the fleet.

This dispenser performs: a sturdy design to ensure proper function in any working condition, a vane pump with incorporated bypass for a high flow rate (up to 90 l/min) and an oval gear meter to ensure maximum precision in measurement. An automatic nozzle with swivel connection, ergonomic and easy to handle, and a water absorption filter completes its components.

PERFORMANCE

UP TO 90 L/MIN	AC
FLOW RATE	VOLTAGE
± 0,5%	BLUETOOTH
ACCURACY	CONNECTION



PACKAGING

CODE	WEIGHT		PACKAGING			N. BOXES / EUROPALLET	
	KG	LBS	MM	INCH	PCS/BOX	✗	
FO0748010	57	125	1480X490X400	58,3X19,3X15,7	1	-	-
FO0748000	61	133	1480X490X400	58,3X19,3X15,7	1	-	-



FILTRATION



TANK MONITORING



HOSE REEL



ACCESSORIES



MERCHANDISE

PIUSI

BIS

ANY BIODIESEL

A

AIR

A

ANTIFREEZE

Ad

AdBlue®

B

BIODIESEL

D

DIESEL

F

FOOD

G

GASOLINE

G

GREASE

K

KEROSENE

O

OIL

W

WATER

W

WINDSCREEN

CHART

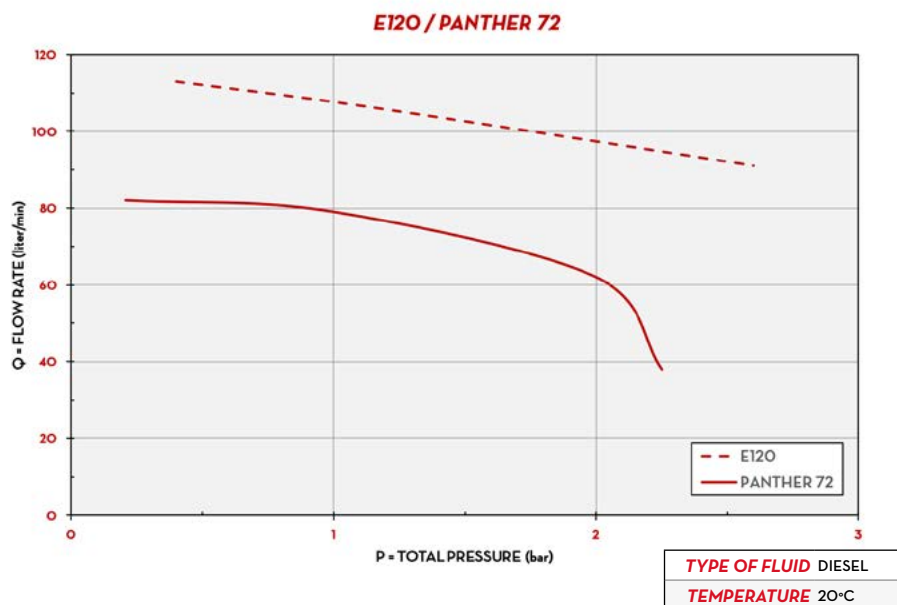

DIMENSIONS

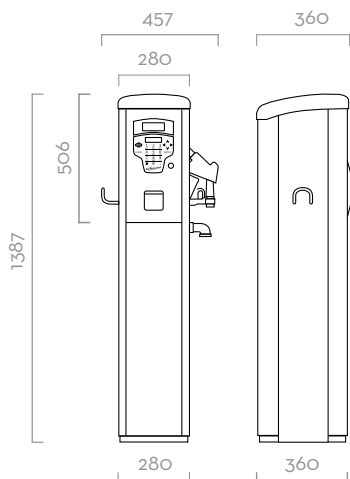

Dimensions expressed in millimeters

IN THE BOX

- SELF SERVICE B.SMART DISPENSER
- DELIVERY HOSE
- AUTOMATIC NOZZLE
- DRIVER ACCESS ADD-ON
- INSTRUCTION MANUAL

DETAILS



SHUTTER



B.SMART MOBILE APP



B.SMART CLOUD SOFTWARE



WATER CAPTOR FILTER

MATERIALS

- **PUMPS:**
PANTHER 72 / E120
- **METER:**
K600/3
- **NOZZLE:**
AUTOMATIC NOZZLE
- **FILTER:**
WATER CAPTOR

TECHNICAL DATA

CODE	DESCRIPTION	FLUIDS TYPE	FLOW RATE		VOLTAGE			PUMP	METER	NOZZLE	FILTER	INLET	HOSE		
			L/MIN	GPM	AC V./HZ	DC VOLT	POWER WATT						AMP. MAX.	LENGTH	Ø
FO0748010	SELF SERVICE 70 230V B.SMART 10 DRIVERS	D	70	18	230 V	50 HZ	550 W	3,3 A	PANTHER 72	K600/3	A80	30 µM	11/2"	4M	25MM
FO0748000	SELF SERVICE 100 230V B.SMART 10 DRIVERS	D	90	24	230 V	50 HZ	1150 W	5,7 A	E120	K600/3	A120	30 µM	11/2"	4M	25MM