



FILTERUNG



TANKÜBERWACHUNG



SCHLAUCHAUFRÖLLER



ZUBEHÖR



MERCHANDISE

PIUSI



ANY BIODIESEL



LUFT



FROSTSCHUTZ



AdBlue®



BIODIESEL



DIESEL



LEBENS.M.



BENZIN



SCHMIERM.



KEROSIN



ÖL



WASSER



WISCHERFLÜSS.

KENNLINIEN

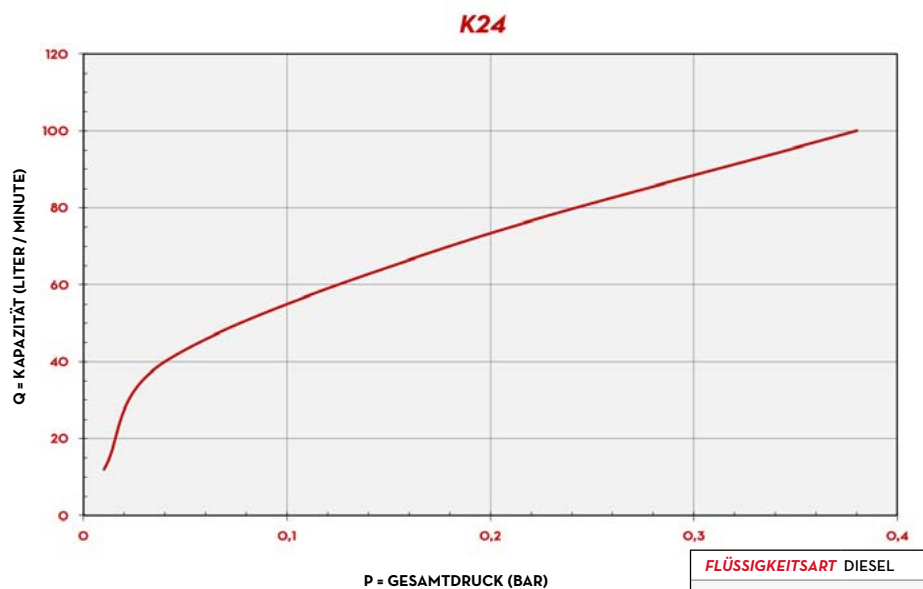

ABMESSUNGEN

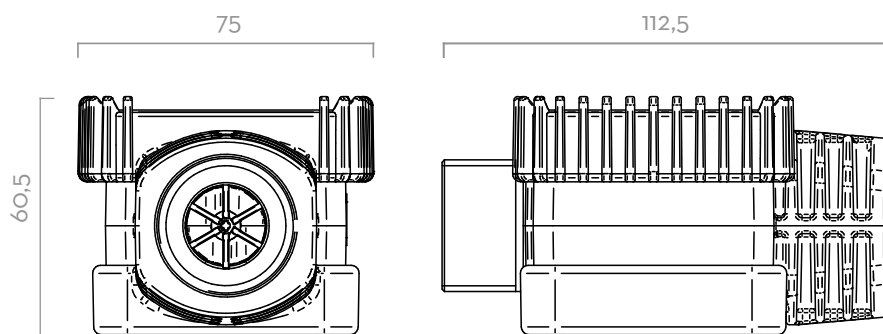

Maße in Millimetern

LIEFERUMFANG

- ZÄHLER K24
- BEDIENUNGSANLEITUNG

EINZELHEITEN



DREHBARES DISPLAY



BIDIREKTIONAL



TURBINEN-IMPULSZÄHLER



F/F-BUCHSE

MATERIALIEN

- GEHÄUSE: ALUMINIUM
- ZÄHNÄDER: TECHNOLYMER

TECHNISCHE DATEN

CODE	BESCHREIBUNG	FLÜSSIGKEITSART	VOLUMENSTROM		DRUCK		BATTERIE 2X AAA BATTERIE 1,5V (INCLUDE)	FLANSCH	BSP EINLASS/AUSLASS
			L/MIN	GPM	BAR	PSI			
K24									
FOO40700A	K24 METER M/MF LITER BLACK 1INBSP		7 - 120	2 - 32	10	150	JA	NEIN	M 1" - M 1"
FOO408100	K24 M/F 1" BSP		7 - 120	2 - 32	20	300	JA	NEIN	M 1" - F 1"
K24 PULSER									
FOO40722A	K24 PULSER M/MF LITER BLACK 1INBSP		7 - 120	2 - 32	10	150	NEIN	NEIN	M 1" - M 1"

AUF ANFRAGE ALS NPTF-AUSFÜHRUNG UND MIT ANZEIGE IN GALLONEN/QUARTERN BZW. PINT ERHÄLTICH * N * 2,1,5-V-BATTERIEN MITGELIEFERT