

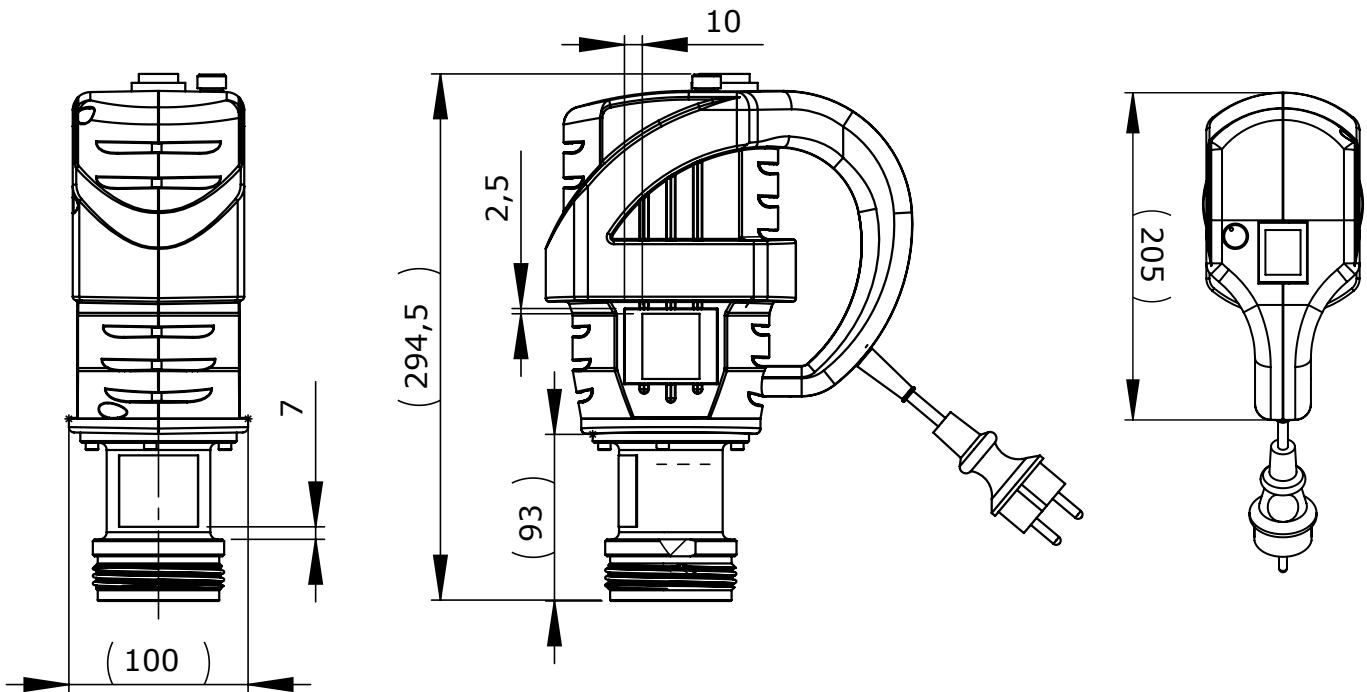

Technical Specifications

Enclosure:	TEFC (IP54)
Voltage:	230V
Power Rating:	950 W
Phase:	1
Nominal Current:	4,5 A
Frequency:	50-60 Hz
Insulation Class:	Class I
Certification:	CE
Housing Material:	Thermoplastic Polyamid
Power Cord Length:	4,0 m
Power Cord Type:	CEE 7/7
Noise Level:	77-84 dBA
Thermal Overload:	Yes
Variable Speed:	SPE-950V:1.000-13.000 rpm
Fixed Speed:	SPE-950: 13.000 rpm
Weight:	3,3 kg



WARNING: Not suitable for pumping flammable or combustible liquids or use in a hazardous duty environment.