



SYSTÈMES DE GESTION DU CARBURANT



DISTRIBUTEURS



KITS



POMPES



COMPTEURS



PISTOLETS

# EX100

## CARACTÉRISTIQUES

- DÉBIT ÉLEVÉ
- RÉSISTANT
- FONCTIONNEMENT CONTINU
- PROTECTION THERMIQUE
- VERSION UL DISPONIBLE
- PÉDALE DE POMPE AMOVIBLE

PIUSI EX100 est la nouvelle pompe de la ligne EX, adaptée au transfert de gasoil et de diesel en cycle continu hautement performant. La directive sur l'utilisation de matériel en atmosphère potentiellement dangereuse est très précise, comme le confirme la certification ATEX. Facile à utiliser, compacte, versatile, elle travaille à haut débit et en cycle continu.

### PERFORMANCES

JUSQU'À  
**100 L/MIN**

DÉBIT

**AC**

TENSION



EX100

NOS POMPES SONT CONFORMES AUX MARQUAGES ATEX/IECEx SUIVANTS

II	2	G	Ex	d	IIA	T4	Gb
GRUPE	CATÉGORIE	TYPE D'ATMOSPHÈRE EXPLOSIBLE	PRÉFIXE PERMANENT	MODE DE PROTECTION	GRUPE DE GAZ	CLASSE DE TEMPÉRATURE	INDICE DE PROTECTION

### PACKAGING

CODE	POIDS		PACKAGING		
	KG	LBS	MM	INCH	PCS/BOÎTE
FO0390010	25	55	240X400X350	9,4X15,7X13,8	1
FO0390020	25	55	240X400X350	9,4X15,7X13,8	1
FO0390030	25	55	240X400X350	9,4X15,7X13,8	1



FILTRAGE



SURVEILLANCE  
DES LIQUIDES



ENROULEUR



ACCESSOIRES



MERCHANDISE

**PIUSI**



ANY BIODIESEL



AIR



ANTIGEL



AdBlue®



BIODIESEL



DIESEL



ALIMENTATION



ESSENCE



GRAISSE



KÉROSÈNE



HUILE



EAU



LAVE-GLACE

## GRAPHIQUE

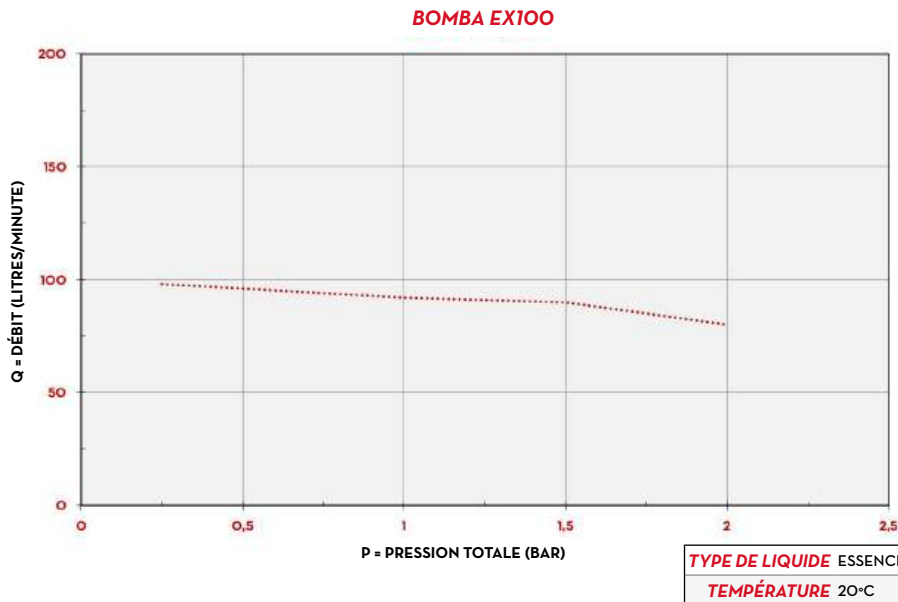

## DIMENSIONS

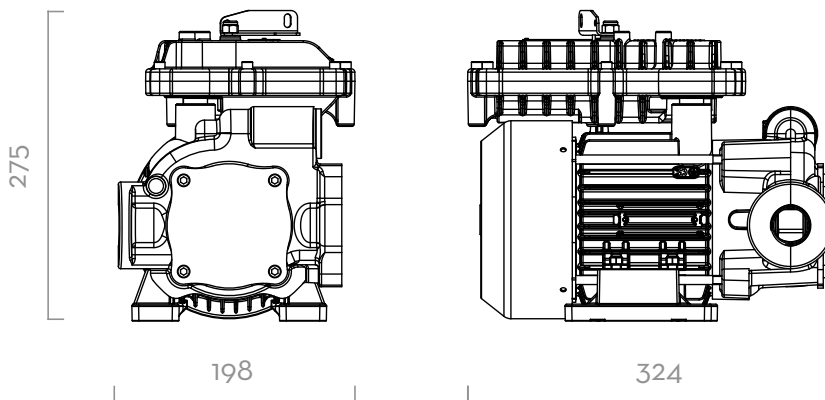

Dimensions exprimées en millimètres

## CONTENU DE L'EMBALLAGE

- POMPE EX100
- PÉDALE DE POMPE
- MANUEL D'INSTRUCTIONS

## DÉTAILS



## MATÉRIAUX

- CORPS: FONTE
- ROTOR: ACIER FRITTÉ
- AUBES: TECHNOLYMER
- JOINT: VITON
- ARBRE: ACIER



POMPE

- > MAX. 6 M (20 FT),
- > TUYAU D'ASPIRATION Ø 1" MIN,
- > HAUTEUR D'ASPIRATION MAX:
  - 2M (7FT) SANS CLAPET ANTI-RETOUR
  - 4M (14FT) AVEC CLAPET ANTI-RETOUR



RÉSERVOIR

## DONNÉES TECHNIQUES

CODE	DESCRIPTION	TYPE DE LIQUIDES	DÉBIT		TENSION			CYCLE DE SERVICE CONTINU	RPM	ENTRÉE		SORTIE
			L/MIN	GPM	AC VOLT/HZ	PUISSANCE WATT	AMP. MAX.			BSP	BSP	
FO0390010	EX 100 230/50 ATEX	D G K	100	25	230/50	1035	4,5	OUI	1450	1" 1/4	1"	
FO0390020	EX 100 230/60 ATEX	D G K	100	25	230/60	874	3,8	OUI	1750	1" 1/4	1"	
FO0390030	EX 100 250/50 ATEX	D G K	100	25	250/50	1000	3,8	OUI	1450	1" 1/4	1"	

(\*) SUR DEMANDE, PRODUIT DISPONIBLE AVEC PLUSIEURS TENSIONS ET FRÉQUENCE DE 60 HZ. LIQUIDES COMPATIBLES : DIESEL, KÉROSÈNE, ESSENCE, MÉLANGE ESSENCE-ALCOOL MAX 15 %, AVGAS 100/100LL, (POMPE SEULEMENT) JET A/A1, (POMPE SEULEMENT) ASPEN 2/4