



FUEL MANAGEMENT SYSTEMS



DISPENSERS



KITS



PUMPS



METERS



NOZZLES

EX100

FEATURES

- HIGH FLOW RATE
- HEAVY DUTY
- CONTINUOUS DUTY
- THERMAL PROTECTION
- UL VERSION AVAILABLE
- REMOVABLE PUMP FEET

PIUSI EX100 is the new pump of the EX line, suitable for the transfer of gasoline and diesel with high performance and continuous duty. The directive on the use of materials in potentially explosive atmospheres is very precise, as confirmed by the ATEX certification. Simple to use, compact, versatile, it performs high flow rate and continuous duty cycle.

PERFORMANCE

UP TO
100 L/MIN

FLOW RATE

AC
VOLTAGE

POWER



EX100

OUR PUMPS COMPLIES WITH THE FOLLOWING MARKING ATEX/IECEX

II	2	G	Ex	d	IIA	T4	Gb
GROUP	CATEGORY	TYPE OF EXPLOSIVE ATMOSPHERE	PERMANENT PREFIX	PROTECTION METHOD	GAS GLASS	TEMPERATURE CLASS	EQUIPMENT PROTECTION LEVEL

PACKAGING

CODE	WEIGHT		PACKAGING		
	KG	LBS	MM	INCH	PCS/BOX
FO0390010	25	55	240X400X350	9,4X15,7X13,8	1
FO0390020	25	55	240X400X350	9,4X15,7X13,8	1
FO0390030	25	55	240X400X350	9,4X15,7X13,8	1



FILTRATION



TANK MONITORING



HOSE REEL



ACCESSORIES



MERCHANDISE

PIUSI

B

ANY BIODIESEL

A

AIR

A

ANTIFREEZE

Ad

AdBlue®

B

BIODIESEL

D

DIESEL

F

FOOD

G

GASOLINE

G

GREASE

K

KEROSENE

O

OIL

W

WATER

W

WINDSCREEN

CHART

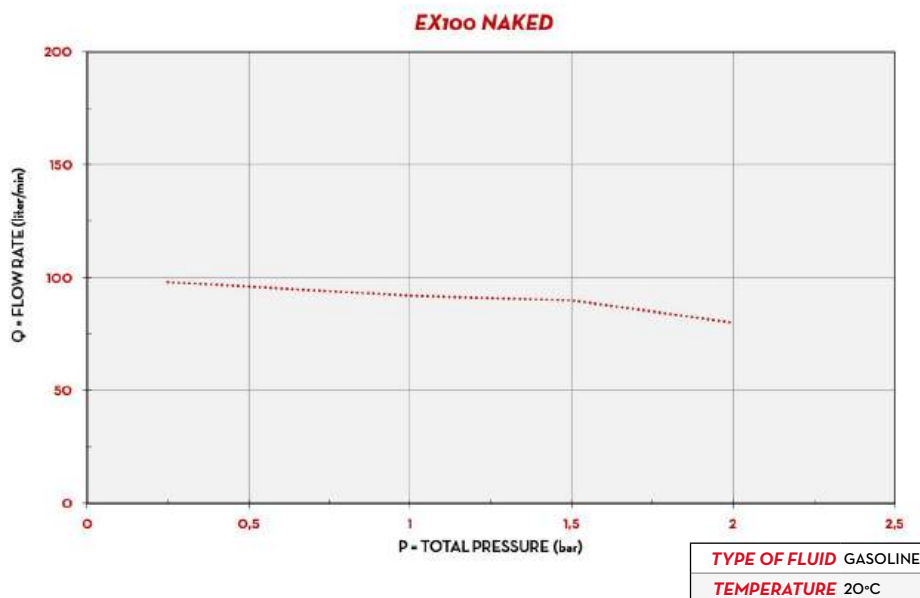

DIMENSIONS

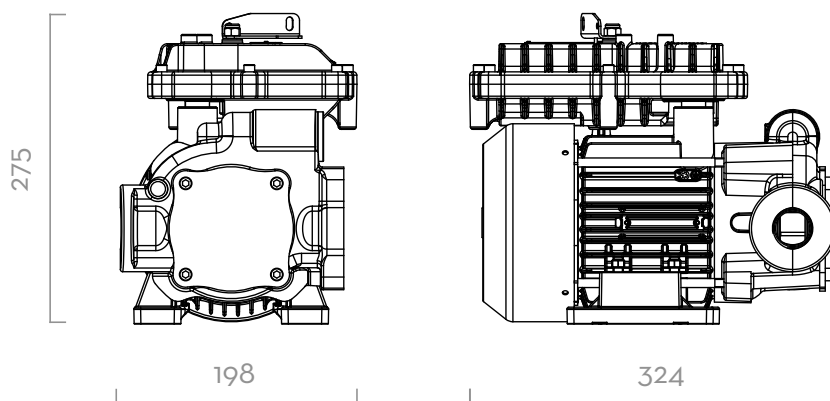

Dimensions expressed in millimeters

IN THE BOX

- EX100 PUMP
- PUMP FEET
- INSTRUCTION MANUAL

DETAILS



ON/OFF SWITCH



VANE ROTOR



BYPASS VALVE

MATERIALS

- BODY: CAST IRON
- ROTOR: SINTERED STEEL
- VANES: TECHNOPOLYMER
- SEAL: VITON
- SHAFT: STEEL



PUMP

- > MAX 6M (20FT),
- > SUCTION HOSE Ø 1" MIN,
- > MAX SUCTION HEIGHT:
 - 2M (7FT) W/O NON RETURN VALVE
 - 4M (14FT) W NON RETURN VALVE



TANK

TECHNICAL DATA

CODE	DESCRIPTION	FLUIDS TYPE	FLOW RATE		VOLTAGE			DUTY CICLE	RPM	INLET		OUTLET
			L/MIN	GPM	AC VOLT/HZ	POWER WATT	AMP. MAX.			CONTINUOUS	BSP	BSP
FO0390010	EX 100 230/50 ATEX	D G K	100	25	230/50	1035	4,5	YES	1450	1" 1/4	1"	
FO0390020	EX 100 230/60 ATEX	D G K	100	25	230/60	874	3,8	YES	1750	1" 1/4	1"	
FO0390030	EX 100 250/50 ATEX	D G K	100	25	250/50	1000	3,8	YES	1450	1" 1/4	1"	

() UPON REQUEST IT IS AVAILABLE WITH DIFFERENT VOLTAGES AND 60 HZ FREQUENCY. COMPATIBLE FLUIDS: DIESEL, KEROSENE, PETROL, PETROL ALCOHOL MIXED MAX 15%, AVGAS 100/100LL (ONLY PUMP), JET A/A1 (ONLY PUMP), ASPEN 2/4