



KRAFTSTOFFMANAGEMENT-SYSTEM



ABGABEEINHEITEN



KITS



PUMPEN



ZÄHLER



ZAPFVENTIL

EX100

MERKMALE

- HOHE FLUSSRATE
- SCHWERLAST
- DAUERBETRIEB
- ÜBERHITZUNGSSCHUTZ
- AUSFÜHRUNG MIT UL LIEFERBAR
- ABNEHMBARE PUMPENFÜSSE

PIUSI EX100 ist die neue Pumpe der EX-Reihe, geeignet für den Transfer von Benzin und Diesel mit hoher Leistung und Dauerbetrieb. Die Richtlinie über die Verwendung von Materialien in explosionsgefährdeten Bereichen ist sehr präzise, was durch die ATEX-Zertifizierung bestätigt wird. Sie ist einfach zu bedienen, kompakt, vielseitig und bietet eine hohe Durchflussrate und einen kontinuierlichen Arbeitszyklus.

LEISTUNGSPARAMETER

BIS ZU
100 L/MIN

VOLUMENSTROM

AC
SPANNUNG

STROMVERSORGUNG



EX100

UNSERE PUMPEN BESITZT DIE FOLGENDEN ATEX-/ECEX-KLASSIFIZIERUNGEN:

II	2	G	Ex	d	IIA	T4	Gb
GRUPPE	KATEGORIE	ART DER EXPLOSIONSGEFÄHRDETEN ATMOSPHERE	PERMANENTES PRÄFIX	SCHUTZ-METHODE	GAS GGLAS	TEMPERATUR-KLASSE	GERÄTESCHUTZSTUFE

VERPACKUNG

CODE	GEWICHT		VERPACKUNG		
	KG	LBS	MM	ZOLL	STCK./KARTON
FO0390010	25	55	240X400X350	9,4X15,7X13,8	1
FO0390020	25	55	240X400X350	9,4X15,7X13,8	1
FO0390030	25	55	240X400X350	9,4X15,7X13,8	1



FILTERUNG



TANKÜBERWACHUNG



SCHLAUCHAUFRÖLLER



ZUBEHÖR



MERCHANDISE

PIUSI



ANY BIODIESEL



LUFT



FROSTSCHUTZ



AdBlue®



BIODIESEL



DIESEL



LEBENSM.



BENZIN



SCHMIERM.



KEROSIN



ÖL



WASSER



WISCHERFLÜSS.

KENNLINIEN

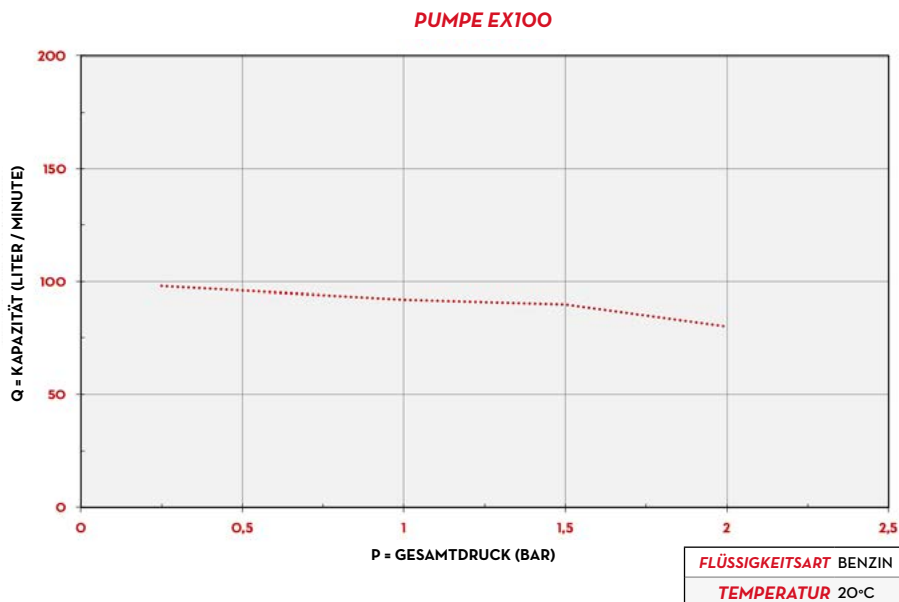

ABMESSUNGEN

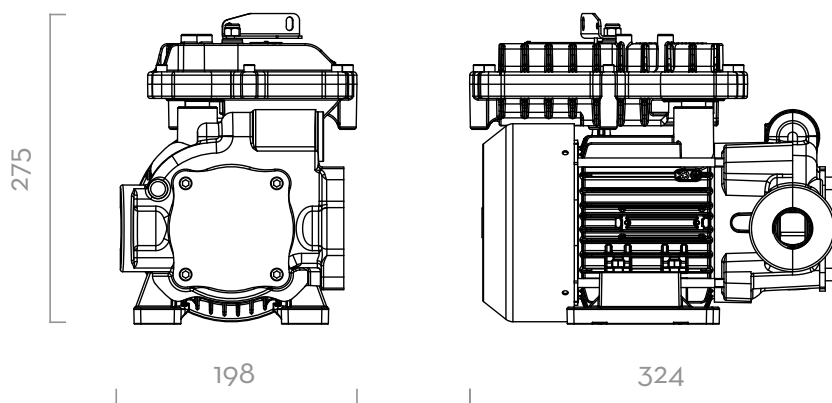

Maße in Millimetern

LIEFERUMFANG

- PUMPE EX100
- PUMPENFÜSSE
- BEDIENUNGSANLEITUNG

EINZELHEITEN



EIN/AUS-SCHALTER



FLÜGELROTOR



BYPASSVENTIL

MATERIALIEN

- GEHÄUSE: GUSSEISEN
- ROTOR: SINTERSTAHL
- FLÜGELZELLEN: TECHNOPYLIMER
- DICHTUNGEN: VITON
- WELLE: STAHL



PUMPE

- > MAX. 6M (20FT),
- > ANSAUGSCHLAUCH Ø 1" MIN.,
- > MAXIMALE SAUGHÖHE:
- 2 M (7 FT) OHNE RÜCKSCHLAGVENTIL
- 4 M (14FT) MIT RÜCKSCHLAGVENTIL



TANK

TECHNISCHE DATEN

CODE	BESCHREIBUNG	FLÜSSIGKEIT-SART	VOLUMENSTROM		SPANNUNG			ARBEIT-SZYKLUS KONTINUIERLICH	DREHZAHL	EINLASS		AUSLASS	
			L/MIN	GPM	AC VOLT/HZ	STROM. WATT	AMP. MAX.			BSP	BSP		
FO0390010	EX 100 230/50 ATEX	D G K	100	25	230/50	1035	4,5	JA	1450	1" 1/4	1"		
FO0390020	EX 100 230/60 ATEX	D G K	100	25	230/60	874	3,8	JA	1750	1" 1/4	1"		
FO0390030	EX 100 250/50 ATEX	D G K	100	25	250/50	1000	3,8	JA	1450	1" 1/4	1"		

AUF ANFRAGE AUCH MIT UNTERSCHIEDLICHER SPANNUNG UND 60 HZ FREQUENZ LIEFERBAR.
VERWENDBARE FLÜSSIGKEITEN: DIESEL, KEROSIN, BENZIN, MAX. 15% BENZINALKOHOL, AVGAS 100 / 100LL (NUR PUMPE) JET A / A1 (NUR PUMPE) ASPEN 2/4