



RIFORMIMENTO  
AUTO



FUEL MANAGEMENT  
SYSTEMS



KITS



POMPE



CONTALITRI



PISTOLE  
CONTALITRI

# SELF SERVICE MC 2.0

## CARATTERISTICHE

- STRUTTURA ROBUSTA
- DISPENSER COMPATTO
- ADATTATORE LAN INTEGRATO
- SPORTELLINO FRONTALE PER UNA FACILE MANUTENZIONE
- SOFTWARE SSM 2.0 RICHIESTO
- IDEALE PER LA GESTIONE DEL CARBURANTE
- IP55

SELF SERVICE MC 2.0 presenta tutte le caratteristiche del famoso sistema MC di PIUSI integrate in un dispenser specifico per AdBlue® garantendo, allo stesso tempo, tutte le funzionalità 2.0: monitoraggio dei consumi di AdBlue®, reportistica, gestione flotta, controllo veicoli e autisti.

### PERFORMANCE

FINO A

**32 L/MIN**

PORTATA

**LAN**

CONNESSIONE

**±1%**

PRECISIONE



SELF SERVICE MC 2.0

### PACKAGING

CODICE	PESO		PACKAGING		N. BOX/EUROPALLET	
	KG	LBS	MM	PEZZI/BOX		
FO074306A	50	110	1478X488X400	1	6*	4



PISTOLE



FILTRAZIONE



MONITORAGGIO FLUIDI



ARROTOLATORI



ACCESSORI



MERCHANDISE



ARIA



ANTIGELO



AdBlue®



BIODIESEL



DIESEL



ALIMENTI



BENZINA



GRASSO



KEROSENE



OLIO



ACQUA



LAVAVETRI

## GRAFICO

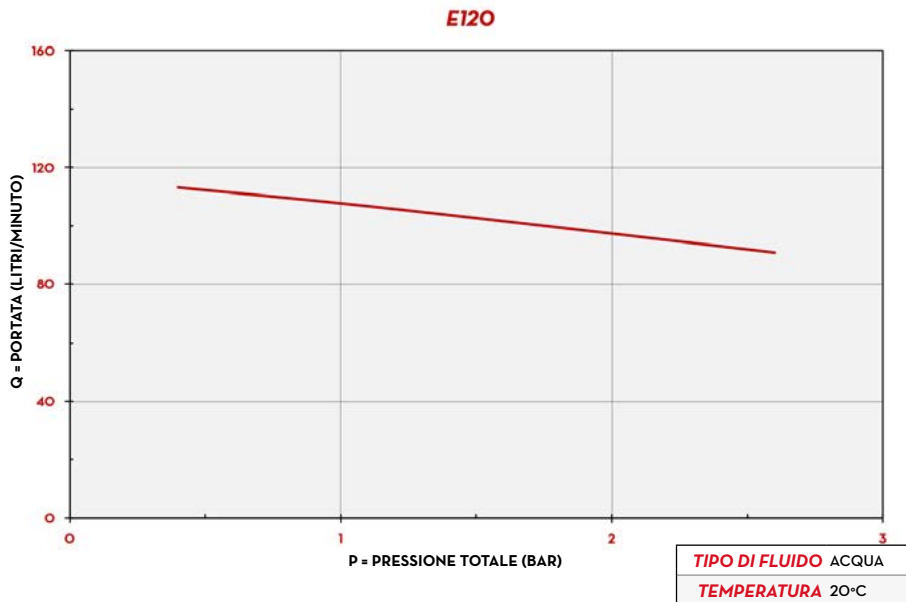

## DIMENSIONI

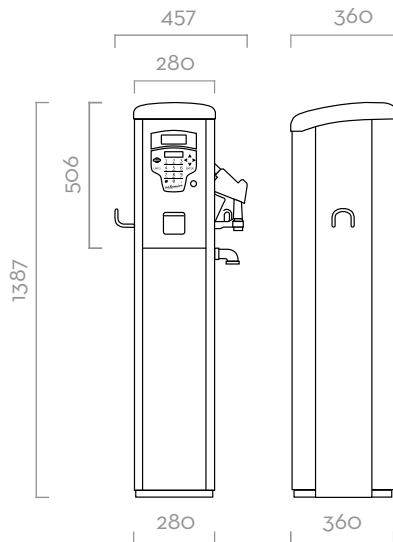

Dimensioni espresse in millimetri

## DENTRO LA SCATOLA

- DISPENSER SELF SERVICE MC 2.0
- TUBO DI MANDATA
- PISTOLA SB325\_X
- MANUALE ISTRUZIONI

## DETTAGLI



PISTOLA SB325\_X



3D FILTER



SSM 2.0 SOFTWARE

## COMPONENTI

- **POMPA:**  
SUZZARABLU PUMP AC
- **CONTALITRI:**  
K24 METER
- **PISTOLA:**  
SB325\_X
- **FILTRO:**  
3D FILTER

## DATI TECNICI

CODICE	DESCRIZIONE	TIPI DI FLUIDO	PORTATA		VOLTAGGIO			CONTALITRI	PISTOLA	FILTRO	INLET	TUBO
			L/MIN	GPM	AC V/ HZ DC VOLT	POTENZA WATT	AMP. MAX.					
FO074306A	SELF SERVICE 70 MC 2.0 FOR ADBLUE		32	8,5	230/50	400	1,95	K24	SB325	SI	3/4"	6 M