



CAR FILLING



FUEL MANAGEMENT SYSTEMS



KITS



PUMPS



METERS



METERED NOZZLES

SUZZARABLU PUMP AC

FEATURES

- **READY TO USE**
- **MULTI-PURPOSE PUMP**
- **SELF PRIMING**
- **BUILT-IN BYPASS VALVE**

The PIUSI SUZZARABLU PUMP AC is the most famous diaphragm pump for AdBlue®. It is equipped with electric motor without any dynamic seals. This solution allows to obtain a reliable industrial pump together with self priming capabilities.

PERFORMANCE

UP TO

32 L/MIN

FLOW RATE

20 MIN

DUTY CYCLE



SUZZARABLU PUMP AC



PACKAGING

CODE	WEIGHT		PACKAGING		N. BOXES/EUROPALLET	
	KG	LBS	MM	PCS/BOX		
FOO203090	7	15,4	350X180X280	1	60	84
FOO203200	7	15,4	350X180X280	1	60	84



NOZZLES



FILTRATION



TANK MONITORING



HOSE REEL



ACCESSORIES



MERCHANDISE



AIR



ANTIFREEZE



AdBlue®



BIODIESEL



DIESEL



FOOD



GASOLINE



GREASE



KEROSENE



OIL



WATER



WINDSCREEN

CHART

SUZZARABLU AC

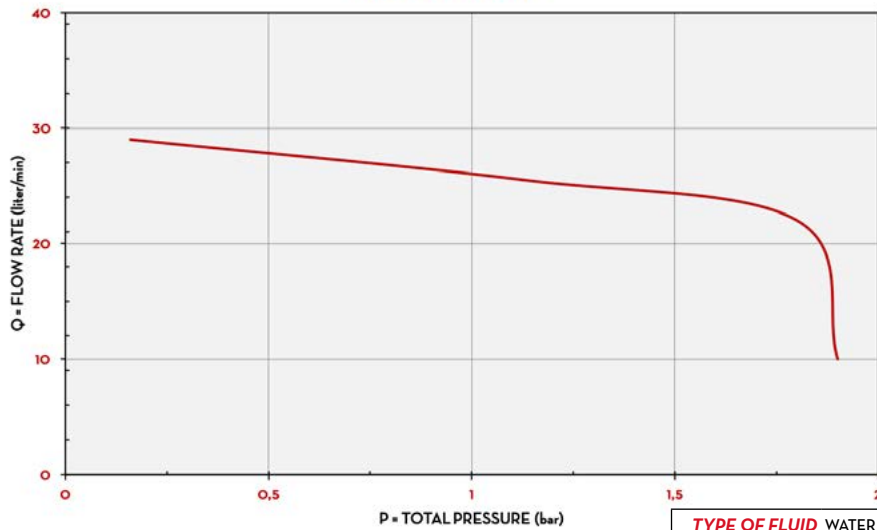

TYPE OF FLUID WATER
TEMPERATURE 20°C

IN THE BOX

- SUZZARABLU PUMP AC
- HOSE FITTINGS
- INSTRUCTION MANUAL

DETAILS



ON/OFF SWITCH



FIXING PLATE

DIMENSIONS

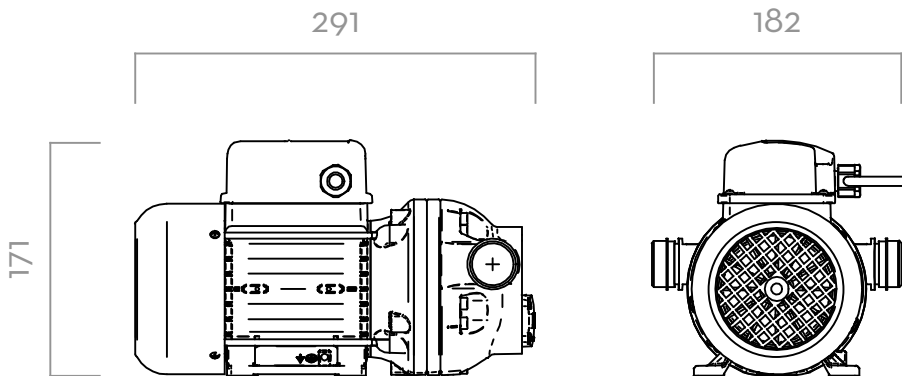

Dimensions expressed in millimeters

MATERIALS

- BODY: POLIPROPYLENE
- DIAPHRAGM: POLIPROPYLENE

TECHNICAL DATA

CODE	DESCRIPTION	FLUIDS TYPE	FLOW RATE		VOLTAGE			CABLES	INLET-OUTLET	ON/OFF	
			L/MIN	GPM	AC V./HZ DC VOLT	RPM	POWER WATT				AMP. MAX.
FOO203090	SUZZARABLU AC PUMP 230/50		32	8,5	230/50	1450	400	1,95	YES	3/4"	YES
FOO203200	POMPA A MEMBRANA N 230/50HZ +CAVO+TIMER		32	8,5	230/50	1450	400	1,95	YES	3/4"	YES

UPON REQUEST IT IS AVAILABLE WITH DIFFERENT VOLTAGE AND FREQUENCY.