



RAVITAILLEMENT DES
AUTOMOBILES



SYSTÈMES DE GESTION
DU CARBURANT



KITS



POMPES



COMPTEURS



PISTOLETS COMPTEURS

SUZZARABLUE PUMP AC

CARACTÉRISTIQUES

- PRÊTE À L'USAGE
- POMPE MULTI-USAGES
- AUTO-AMORÇANTE
- VANNE DE DÉRIVATION INTÉGRÉE

PIUSI SUZZARABLUE PUMP AC de PIUSI est la pompe à diaphragme la plus connue pour AdBlue®. Elle est dotée d'un moteur électrique sans joints dynamiques. Cette solution permet d'obtenir une pompe industrielle fiable avec des capacités auto-amorçantes.

PERFORMANCES

JUSQU'À

32 L/MIN

DÉBIT

20 MIN

CYCLE DE SERVICE



SUZZARABLUE PUMP AC



PACKAGING

CODE	POIDS		PACKAGING		N. BOXES/EUROPALLET	
	KG	LBS	MM	PCS/BOÎTE		
FO0203090	7	15,4	350X180X280	1	60	84



PISTOLETS



FILTRAGE

SURVEILLANCE
DES LIQUIDES

ENROULEURS



ACCESSOIRES



MERCHANDISE



AIR



ANTIGEL



AdBlue®



BIODIESEL



DIESEL



ALIMENTATION



ESSENCE



GRAISSE



KÉROSÈNE



HUILE



EAU



LAVE-GLACE

GRAPHIQUES

SUZZARABLUÉ AC

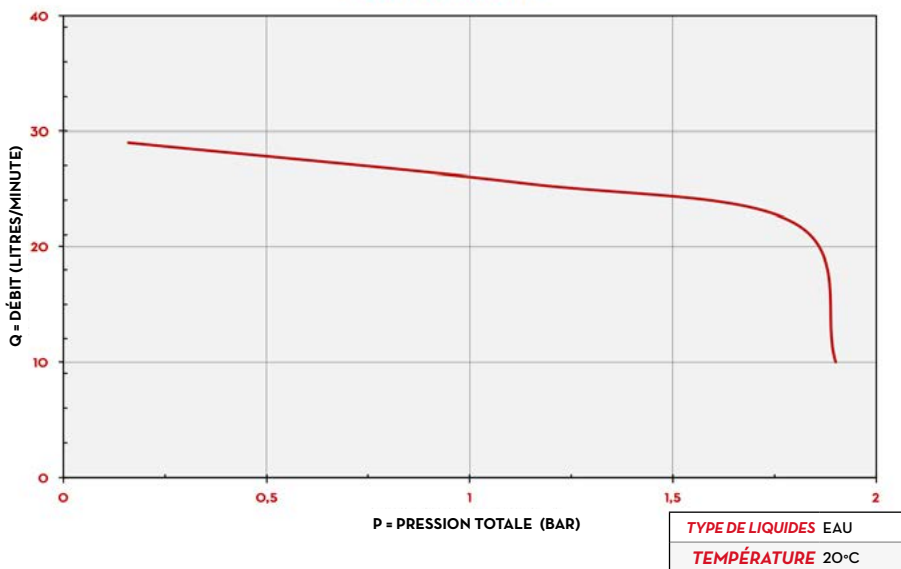

CONTENU DE L'EMBALLAGE

- POMPE SUZZARABLUÉ AC
- RACCORDS DE TUYAU
- MANUEL D'INSTRUCTIONS

DÉTAILS



INTERRUPTEUR ON/OFF



PLAQUE DE FIXATION

DIMENSIONS

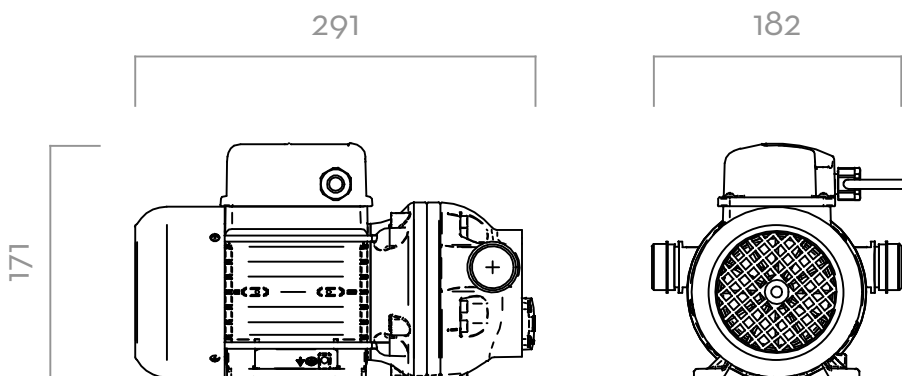

Dimensions exprimées en millimètres

MATÉRIAUX

- CORPS: POLYPROPYLÈNE
- MEMBRANE: POLYPROPYLÈNE

DONNÉES TECHNIQUES

CODE	DESCRIPTION	TYPE DE LIQUIDES	DÉBIT		TENSION				CÂBLE MOD.	ENTRÉE/SORTIE BSP	ON/OFF INTERRUPTEUR
			L/MIN	GPM	AC V/HZ DC VOLT	RPM	PUISSANCE WATT	AMP. MAX.			
FOO203090	SUZZARABLUÉ AC PUMP 230/50		32	8,5	230/50	1450	400	1,95	OUI	3/4"	OUI

SUR DEMANDE, PRODUIT DISPONIBLE AVEC DIFFÉRENTES TENSIONS ET FRÉQUENCES.

SUZZARABLUÉ PUMP AC