



AUTOBETANKUNG



KRAFTSTOFFMANAGEMENT-SYSTEM



KITS



PUMPEN



ZÄHLER



ZAPFVENTILZÄHLER

SUZZARABLUE PUMP AC

MERKMALE

- SOFORT EINSATZBEREIT
- MEHRZWECKPUMPE
- SELBSTANSAUGEND
- EINGEBAUTES BYPASS-VENTIL

Die PIUSI SUZZARABLUE PUMP AC ist die bekannteste Membranpumpe für AdBlue®. Sie ist mit einem Elektromotor ohne dynamische Dichtungen ausgestattet. Mit dieser Lösung erhält man eine zuverlässige Industriepumpe mit Selbstansaugung.

LEISTUNGSPARAMETER

BIS ZU

32 L/MIN

VOLUMENSTROM

20 MIN

ARBEITSZYKLUS



SUZZARABLUE PUMP AC



VERPACKUNG

CODE	GEWICHT		VERPACKUNG		N. BOXES/EUROPALLET	
	KG	LBS	MM	STCK./KARTON		
FO0203090	7	15,4	350X180X280	1	60	84



ZAPFVENTILE



FILTERUNG



FLÜSSIGKEIT-SÜBERWACHUNG



SCHLAUCHAUFROLLER



ZUBEHÖR



MERCHANDISE



LUFT



FROSTSCHUTZ



AdBlue®



BIODIESEL



DIESEL



LEBENS.M.



BENZIN



SCHMIERM.



KEROSIN



ÖL



WASSER



WISCHERFLÜSS.

KENNLINIEN

LIEFERUMFANG

- SUZZARABLUE PUMP AC
- SCHLAUCHANSCHLÜSSE
- BEDIENUNGSANLEITUNG

EINZELHEITEN



EIN/AUS-SCHALTER



BEFESTIGUNGSPLATTE

MATERIALIEN

- GEHÄUSE: POLIPROPYLENE
- MEMBRAN: POLIPROPYLENE

SUZZARABLUE AC

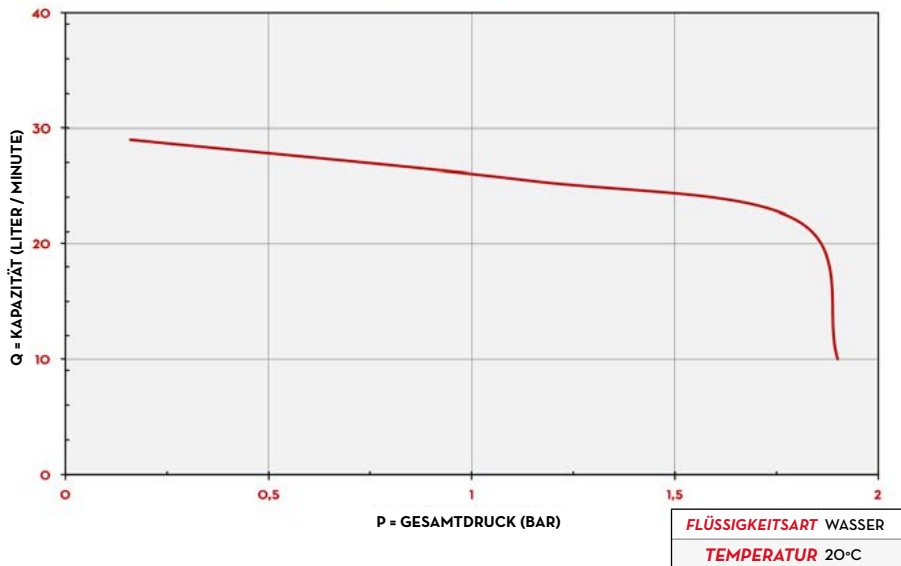

ABMESSUNGEN

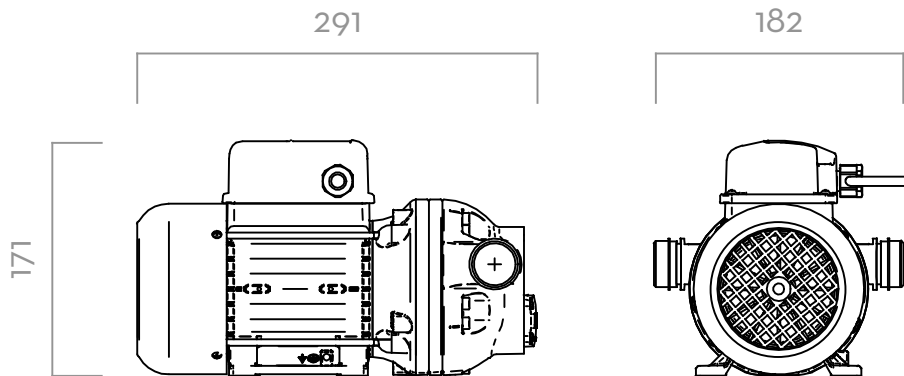

Maße in Millimetern

TECHNISCHE DATEN

CODE	BESCHREIBUNG	FLÜSSIGKEITSART	VOLUMENSTROM		SPANNUNG				KABEL MOD.	EINGANG/AUSGANG BSP	EIN/AUS SWITCH
			L/MIN	GPM	AC V/Hz DC VOLT	RPM	POWER WATT	AMP. MAX.			
FO0203090	SUZZARABLUE AC PUMP 230/50	Ad W	32	8,5	230/50	1450	400	1,95	JA	3/4"	JA

AUF ANFRAGE AUCH MIT UNTERSCHIEDLICHER SPANNUNG UND FREQUENZ LIEFERBAR

SUZZARABLUE PUMP AC