



CAR FILLING



FUEL MANAGEMENT SYSTEMS



KITS



PUMPS



METERS



METERED NOZZLES

SUZZARABLUE DRUM

FEATURES

- DESIGNED FOR 200 L DRUM
- EASY TO INSTALL
- SUZZARABLUE PUMP

The PIUSI SUZZARABLUE DRUM is the solution for all the AdBlue® drum applications. Its adjustable bracket allows an easy installation on any kind of barrel.

PERFORMANCE

UP TO

32 L/MIN

FLOW RATE

AC
VOLTAGE
POWER

20 MIN

DUTY CYCLE



SUZZARABLUE DRUM

PACKAGING

CODE	WEIGHT		PACKAGING		
	KG	LBS	MM	INCH	PCS/BOX
FOO20135E	16	35,3	470X370X265	18,3X14,6X10,4	1
FOO201D5C	16	35,3	470X370X265	18,3X14,6X10,4	1
FOO201E5C	16	35,3	470X370X265	18,3X14,6X10,4	1



NOZZLES



FILTRATION



TANK MONITORING



HOSE REEL



ACCESSORIES



MERCHANDISE



AIR



ANTIFREEZE



AdBlue®



BIODIESEL



DIESEL



FOOD



GASOLINE



GREASE



KEROSENE



OIL



WATER



WINDSCREEN

CHART

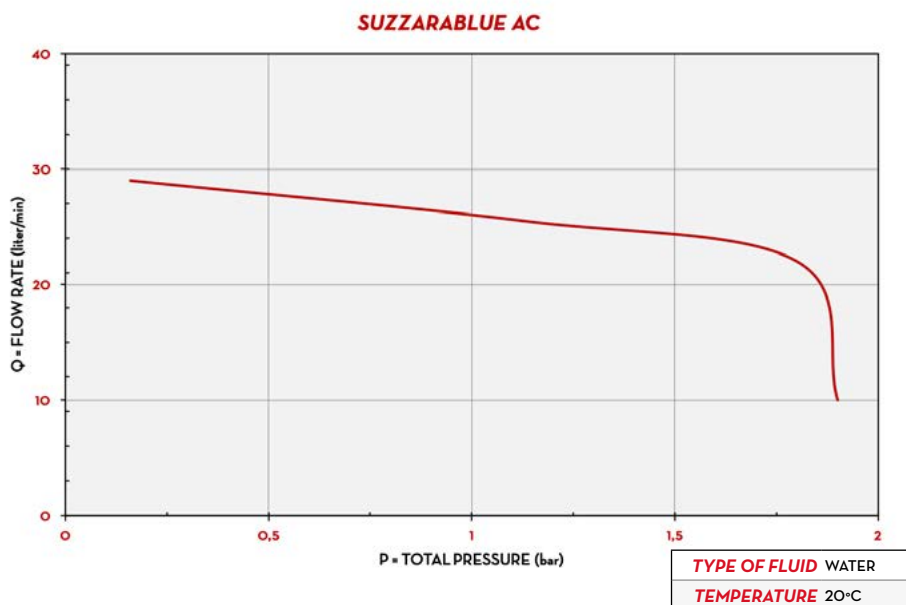

DIMENSIONS

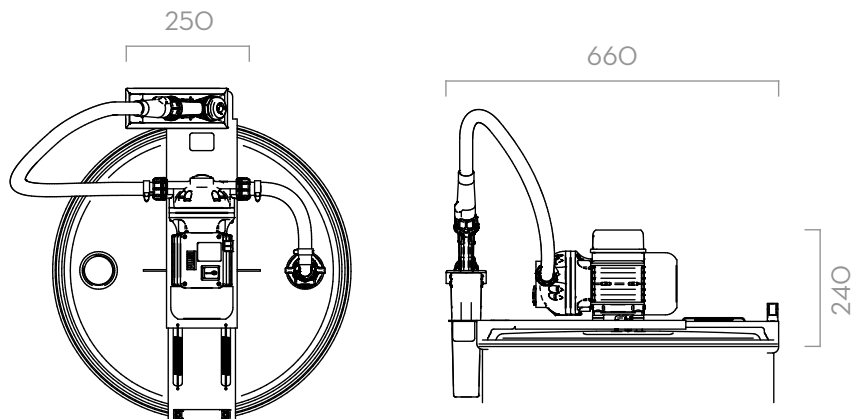

Dimensions expressed in millimeters

IN THE BOX

- SUZZARABLU DRUM UNIT
- SB325_X / SB325_X METER NOZZLE (ON REQUEST)
- AF2 CONNECTOR
- SUCTION PIPE
- DELIVERY HOSE
- INSTRUCTION MANUAL

DETAILS



SUZZARABLU PUMP AC



AF2 CONNECTOR



SUCTION PIPE

COMPONENTS

- **PUMP:**
SUZZARABLU PUMP AC
- **NOZZLE:**
SB325_X METER
SB325_X
SUZZARABLU MANUAL NOZZLE

TECHNICAL DATA

CODE	DESCRIPTION	FLUIDS TYPE	FLOW RATE		VOLTAGE			METER MOD.	NOZZLE TYPE	CONNECTOR	HOSE		ON/OFF SWITCH
			L/MIN	GPM	AC V./HZ DC VOLT	POWER WATT	AMP. MAX.				LENGHT	Ø	
FOO20135E	SUZZARABLU DRUM 230V/50HZ		32	8,5	230/50	400	1.95	NO	MAN.	AF2	6 M	3/4"	YES
FOO201D5C	SUZZARABLU DRUM 230V/50HZ - SB325_X		32	8,5	230/50	400	1.95	NO	SB325	AF2	6 M	3/4"	YES
FOO201E5C	SUZZARABLU DRUM 230V/50HZ - SB325_X MET		32	8,5	230/50	400	1.95	SB325_X	SB325_X	AF2	6 M	3/4"	YES