



AUTOBETANKUNG



KRAFTSTOFFMANAGEMENT-SYSTEM



KITS



PUMPEN



ZÄHLER



ZAPFVENTILZÄHLER

# SUZZARABLUE DRUM

## MERKMALE

- FÜR 200 L FÄSSER
- LEICHT INSTALLIERBAR
- SUZZARABLUE PUMPE

Die PIUSI SUZZARABLUE DRUM ist die Lösung für AdBlue® in Fässern. Ihre verstellbare Halterung ermöglicht eine einfache Installation an allen Fassarten.

## LEISTUNGSPARAMETER

BIS ZU

**32 L/MIN**

VOLUMENSTROM

**AC**

**STROMVERSORGUNG**

SPANNUNG

**20 MIN**

ARBEITSZYKLUS



**SUZZARABLUE DRUM**

## VERPACKUNG

CODE	GEWICHT		VERPACKUNG		
	KG	LBS	MM	ZOLL	STCK./KARTON
FOO20135E	16	35,3	470X370X265	18,3X14,6X10,4	1
FOO201D5C	16	35,3	470X370X265	18,3X14,6X10,4	1
FOO201E5C	16	35,3	470X370X265	18,3X14,6X10,4	1



ZAPFVENTILE



FILTERUNG

FLÜSSIGKEIT-  
SÜBERWACHUNG

SCHLAUCHAUFROLLER



ZUBEHÖR



MERCHANDISE



LUFT



FROSTSCHUTZ



AdBlue®



BIODIESEL



DIESEL



LEBENS.M.



BENZIN



SCHMIERM.



KEROSIN



ÖL



WASSER



WISCHERFLÜSS.

## KENNLINIEN

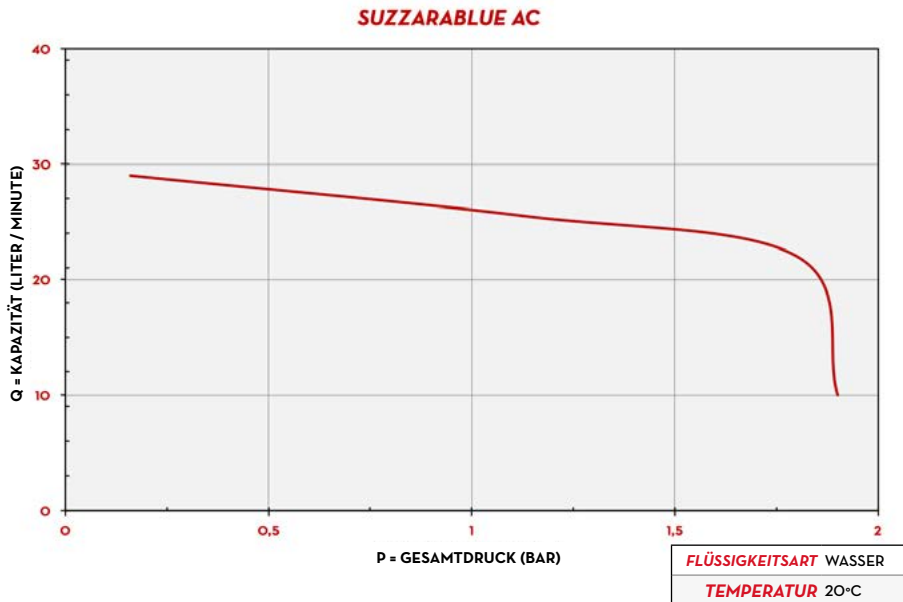

## ABMESSUNGEN

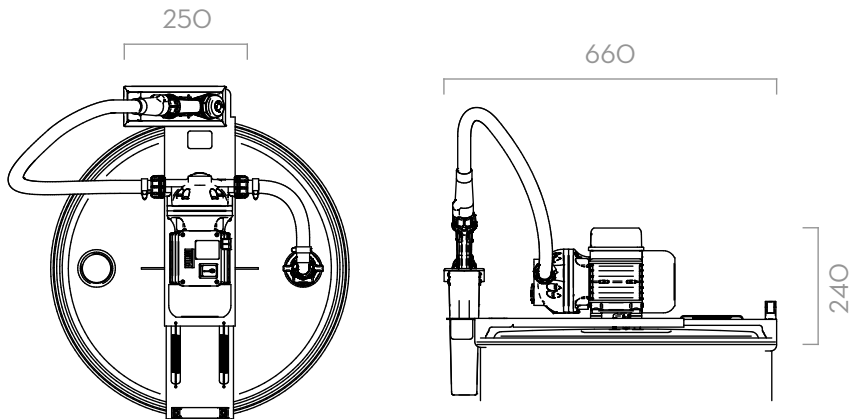

Maße in Millimetern

## LIEFERUMFANG

- SUZZARABLUE DRUM EINHEIT
- SB325\_X / SB325\_X METER ZAPFVENTIL (AUF ANFRAGE)
- AF2-ANSCHLUSS
- SAUGROHR
- VERSORGUNGSSCHLAUCH
- BEDIENUNGSANLEITUNG

## EINZELHEITEN



## KOMPONENTEN

- PUMPE:  
SUZZARABLUE PUMP AC
- ZAPFVENTIL:  
SB325\_X METER  
SB325\_X  
SUZZARABLUE MANUAL NOZZLE

## TECHNISCHE DATEN

CODE	BESCHREIBUNG	FLÜSSIGKEITSART	VOLUMENSTROM		SPANNUNG			ZÄHLER	ZAPFVENTIL	3D FILTER	SCHLAUCH		EIN/AUS SWITCH
			L/MIN	GPM	AC V./HZ	DC VOLT	POWER WATT				AMP. MAX.	LÄNGE.	
FOO20135E	SUZZARABLUE DRUM 230V/50HZ		32	8,5	230/50	400	495	NEIN	MAN.	AF2	6 M	3/4"	JA
FOO201D5C	SUZZARABLUE DRUM 230V/50HZ - SB325_X		32	8,5	230/50	400	495	NEIN	SB325	AF2	6 M	3/4"	JA
FOO201E5C	SUZZARABLUE DRUM 230V/50HZ - SB325_X MET		32	8,5	230/50	400	495	NEIN	SB325	AF2	6 M	3/4"	JA