



AUTOBETANKUNG



KRAFTSTOFFMANAGEMENT-SYSTEM



KITS



PUMPEN



ZÄHLER



ZAPFVENTILZÄHLER

SUZZARABLUE DRUM

MERKMALE

- FÜR 200 L FÄSSER
- LEICHT INSTALLIERBAR
- SUZZARABLUE PUMPE

Die PIUSI SUZZARABLUE DRUM ist die Lösung für AdBlue® in Fässern. Ihre verstellbare Halterung ermöglicht eine einfache Installation an allen Fassarten.

LEISTUNGSPARAMETER

BIS ZU

32 L/MIN

VOLUMENSTROM

AC

STROMVERSORGUNG

SPANNUNG

20 MIN

ARBEITSZYKLUS



SUZZARABLUE DRUM

VERPACKUNG

CODE	GEWICHT		VERPACKUNG		
	KG	LBS	MM	ZOLL	STCK./KARTON
FOO20135E	16	35,3	470X370X265	18,3X14,6X10,4	1
FOO201D5C	16	35,3	470X370X265	18,3X14,6X10,4	1
FOO201E5C	16	35,3	470X370X265	18,3X14,6X10,4	1



ZAPFVENTILE



FILTERUNG

FLÜSSIGKEIT-
SÜBERWACHUNG

SCHLAUCHAUFROLLER



ZUBEHÖR



MERCHANDISE



LUFT



FROSTSCHUTZ



AdBlue®



BIODIESEL



DIESEL



LEBENS.M.



BENZIN



SCHMIERM.



KEROSIN



ÖL



WASSER



WISCHERFLÜSS.

KENNLINIEN

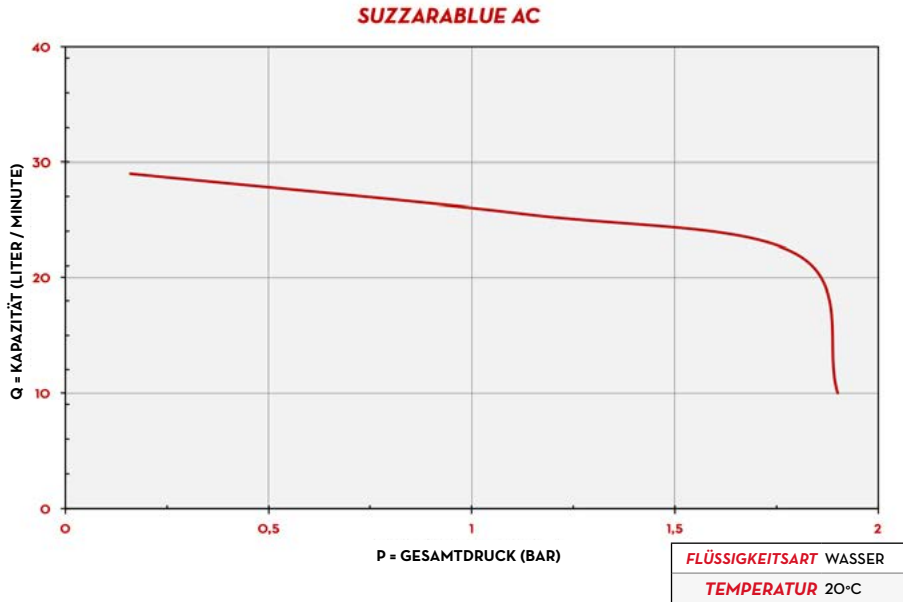

ABMESSUNGEN

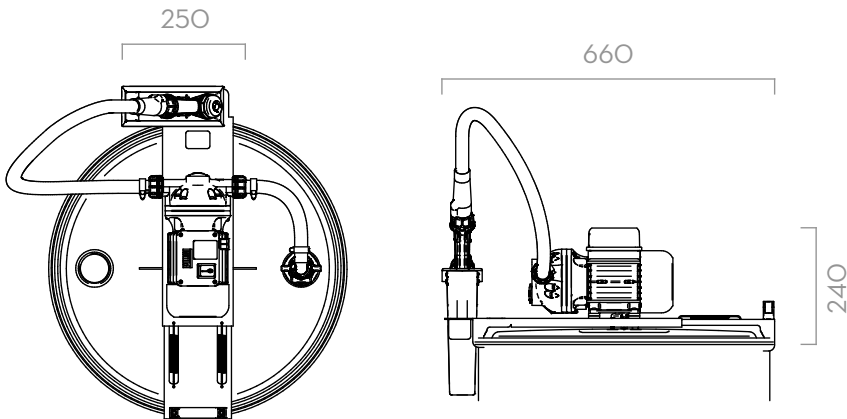

Maße in Millimetern

LIEFERUMFANG

- SUZZARABLUE DRUM EINHEIT
- SB325_X / SB325_X METER ZAPFVENTIL (AUF ANFRAGE)
- AF2-ANSCHLUSS
- SAUGROHR
- VERSORGUNGSSCHLAUCH
- BEDIENUNGSANLEITUNG

EINZELHEITEN



KOMPONENTEN

- PUMPE:
SUZZARABLUE PUMP AC S. 70
- ZAPFVENTIL:
SB325_X METER S. 106
SB325_X S. 116
SUZZARABLUE MANUAL NOZZLE S. 120

TECHNISCHE DATEN

CODE	BESCHREIBUNG	FLÜSSIGKEITSART	VOLUMENSTROM		SPANNUNG			ZÄHLER MOD.	ZAPFVENTIL TYPE	3D FILTER	SCHLAUCH		EIN/AUS SWITCH
			L/MIN	GPM	AC V./HZ DC VOLT	POWER WATT	AMP. MAX.				LÄNGE.	Ø	
FOO20135E	SUZZARABLUE DRUM 230V/50HZ		32	8,5	230/50	400	495	NEIN	MAN.	AF2	6 M	3/4"	JA
FOO201D5C	SUZZARABLUE DRUM 230V/50HZ - SB325_X		32	8,5	230/50	400	495	NEIN	SB325	AF2	6 M	3/4"	JA
FOO201E5C	SUZZARABLUE DRUM 230V/50HZ - SB325_X MET		32	8,5	230/50	400	495	NEIN	SB325	AF2	6 M	3/4"	JA

SUZZARABLUE DRUM