



FUEL MANAGEMENT SYSTEMS



DISPENSERS



KITS



POMPE



CONTALIBRI



PISTOLE

EX50 AC

CARATTERISTICHE

- DESIGN COMPATTO E ROBUSTO
- COMPONENTI FLANGIATI
- FILTRO ANTIDISTURBO
- PROTEZIONE TERMICA
- UNITÀ DI ASPIRAZIONE CON FILTRO INTEGRATO (VERSIONE FUSTO)
- DISPONIBILE VERSIONE UL

PIUSI EX50 AC è una pompa compatta e robusta che soddisfa i più severi requisiti ATEX/IECEx relativi all'utilizzo di questa attrezzatura in atmosfere potenzialmente esplosive. È dotato di valvola di bypass integrata, valvola di non ritorno e filtro antidisturbo.

PERFORMANCE

FINO A

50 L/MIN

PORTATA

AC

VOLTAGGIO

POTENZA

30 MIN

(30MIN OFF)

CICLO DI LAVORO

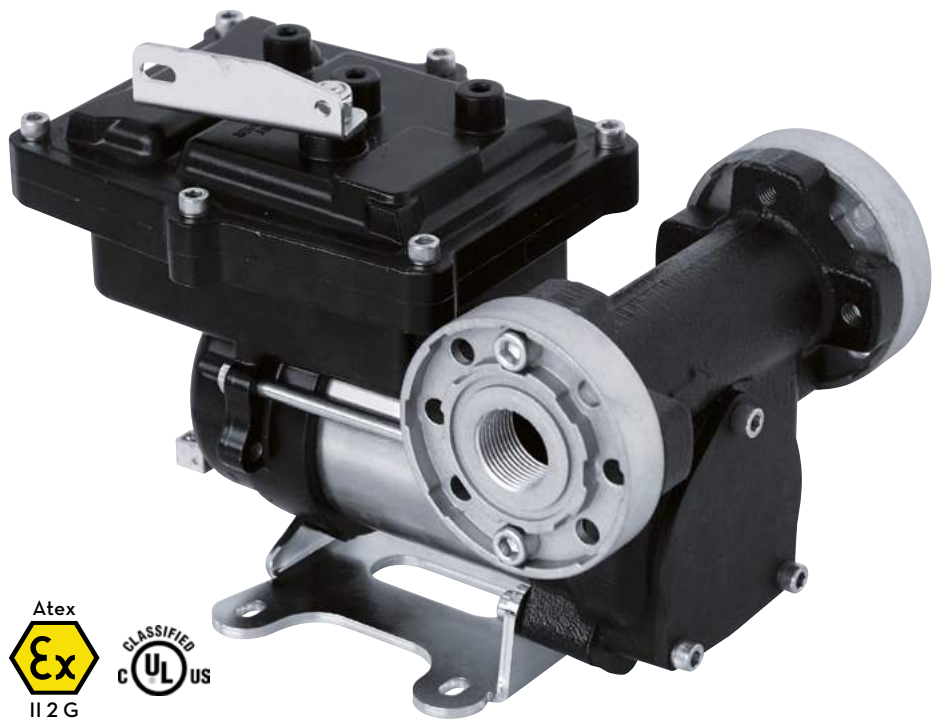



EX50 AC



LE NOSTRE POMPE SONO CONFORMI ALLA MARCATURA ATEX / IECEx

II	2	G	Ex	d	db	IIA	IIB	T4	Gb
GRUPPO	CATEGORIA	TIPO DI ATMOSFERA ESPLOSIVA	PREFISSO PERMANENTE	METODO DI PROTEZIONE	CLASSE DI GAS	CLASSE DI TEMPERATURA	LIVELLO DI PROTEZIONE DELL'ATTREZZATURA		

PACKAGING

CODICE	PESO		PACKAGING			N. BOX / EUROPALLET	
	KG	LBS	MM	INCH	PCS/BOX		
FO037300A	6,9	15,2	345X175X225	-	1	60	84



FILTRAZIONE



MONITORAGGIO FLUIDI



ARROTOLATORI



ACCESSORI



MERCHANDISE



ARIA



ANTIGELO



AdBlue®



BIODIESEL



DIESEL



ALIMENTI



BENZINA



GRASSO



KEROSENE



OLIO



ACQUA



LAVAVETRI

GRAFICO

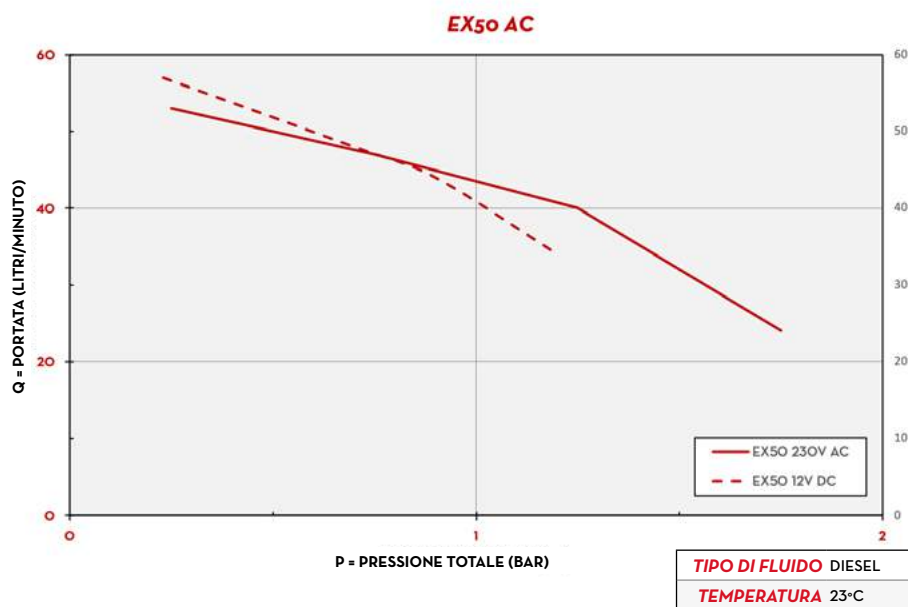

DENTRO LA SCATOLA

- POMPA EX50 AC
- COLLEGAMENTI FLANGIATI
- MANUALE ISTRUZIONI

DETTAGLI



SELETTORE ON/OFF



CONNESSIONI FLANGIATE

DIMENSIONI

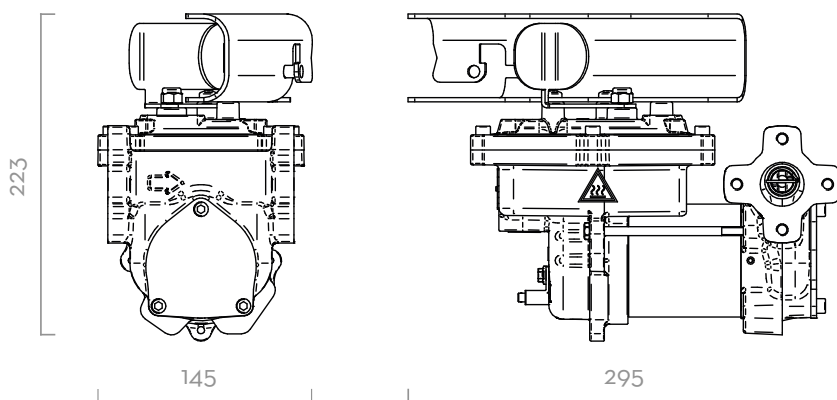

Dimensioni espresse in millimetri

MATERIALI

- CORPO: GHISA
- ROTORE: ACCIAIO SINTERIZZATO
- PALETTE: PPS
- GUARNIZIONE: VITON
- ALBERO: ACCIAIO



POMPA

- MASSIMO 6M (20FT),
- TUBO DI ASPIRAZIONE Ø 1" MIN,
- MASSIMA ALTEZZA D'ASPIRAZIONE:
 - 2M (7FT) SENZA VALVOLA DI NON RITORNO
 - 4M (14FT) CON VALVOLA DI NON RITORNO



FUSTO

DATI TECNICI

CODICE	DESCRIZIONE	TIPO DI FLUIDO	PORTATA		VOLTAGGIO			CICLO DI LAVORO (MINUTI)	RPM	OUTLET (BSP)
			L/MIN	GPM	AC VOLT/HZ	POTENZA WATT	AMP. MAX.			
FO037300A	EX50 230V AC ATEX	D G K	50	13	230/50-60	250	1,2	30	2700	1"

(*) SU RICHIESTA È DISPONIBILE CON DIVERSI VOLTAGGIO E FREQUENZA 60 HZ. LA POMPA PUÒ ESSERE UTILIZZATA SOLO CON SEGUENTI FLUIDI: DIESEL, CHEROSENE, BENZINA, ALCOOL MISTO BENZINA MAX 15%, AVGAS 100 / 100LL, JET A / A1 - ASPEN 2/4

EX50 AC