



AUTOBETANKUNG



KRAFTSTOFFMANAGEMENT-SYSTEM



KITS



PUMPEN



ZÄHLER



ZAPFVENTILZÄHLER

# SB325\_X METER

## MERKMALE

- LEISTUNGSSTARK
- VIELSEITIG
- EINGEBAUTER TURBINENZÄHLER
- BREAK-AWAY SYSTEM
- MULTIFUNKTIONSDISPLAY

Der PIUSI SB325\_X METER ist der patentierte Automatik-Zapfventilzähler von PIUSI für AdBlue®. Er besteht aus einem innovativen Gehäuse aus Technopolymer, einem Abreißsystem, einem Auslauf aus Edelstahl und dem Zähler PIUSI K24 mit  $\pm 1\%$  Genauigkeit. Die Sicherheit wird durch das break-away system gewährleistet. Falls ein Fahrzeug versehentlich mit dem noch im Tank befindlichen Zapfventil wegfährt, löst sich das Auslaufrohr vom Zapfventil. Dieses System ermöglicht auch eine schnelle Reparatur, da lediglich ein neues Auslaufrohr am Zapfventil angebracht werden muss.

## LEISTUNGSPARAMETER

BIS ZU

**45 L/MIN**

VOLUMENSTROM

**3,5 BAR**

MAX  
DRUCK

**$\pm 1\%$**

GENAUIGKEIT



SB325\_X METER



## VERPACKUNG

CODE	GEWICHT		VERPACKUNG		
	KG	LBS	MM	ZOLL	STCK./KARTON
FOO61701A	1,0	2,2	447X178X63	17,6X7X2,5	1



ZAPFVENTILE



FILTERUNG



FLÜSSIGKEIT-SÜBERWACHUNG



SCHLAUCHAUFROLLER



ZUBEHÖR



MERCHANDISE



LUFT



FROSTSCHUTZ



AdBlue®



BIODIESEL



DIESEL



LEBENS.M.



BENZIN



SCHMIERM.



KEROSIN



ÖL



WASSER



WISCHERFLÜSS.

## KENNLINIEN

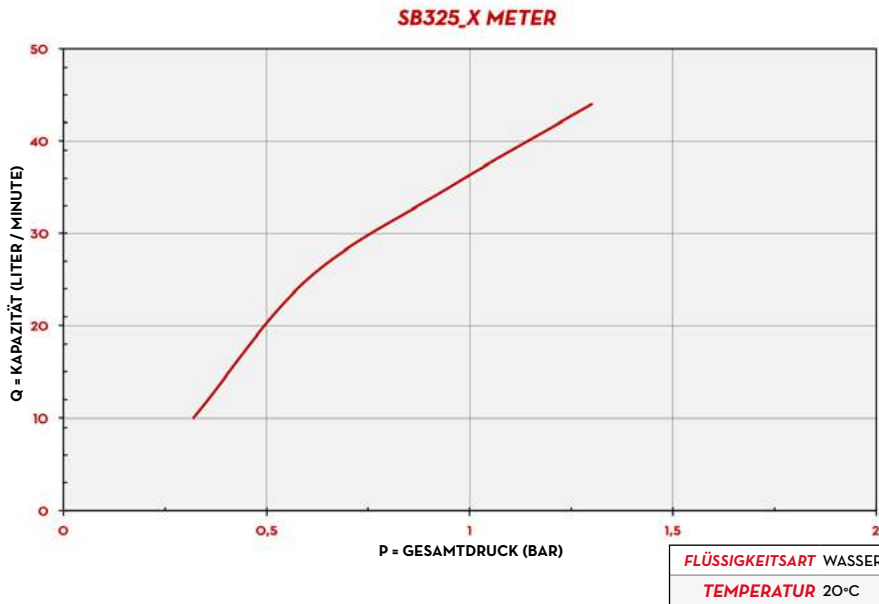

## LIEFERUMFANG

- SB325\_X METER
- BEDIENUNGSANLEITUNG

## EINZELHEITEN



MULTIFUNKTIONS-DISPLAY



BREAK-AWAY SYSTEM

## ABMESSUNGEN

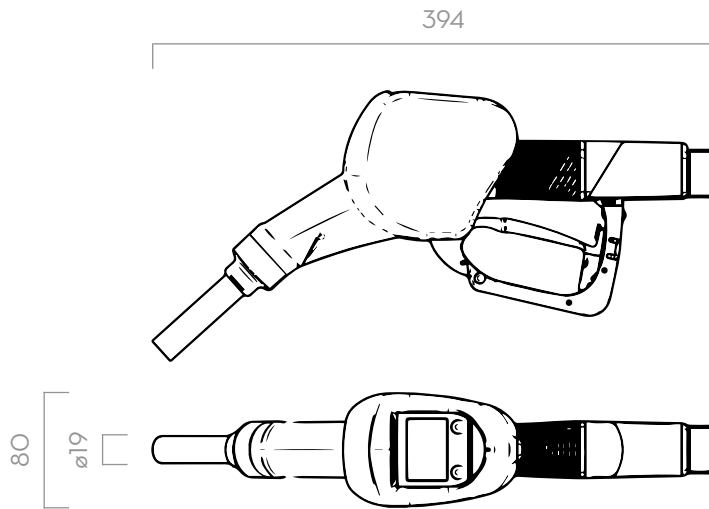

Maße in Millimetern

## MATERIALIEN

- AUSLAUFROHR: EDELSTAHL
- GEHÄUSE: TECHNOPLYMER
- TURBINE: TECHNOPLYMER

## TECHNISCHE DATEN

CODE	BESCHREIBUNG	FLÜSSIGKEITSART	VOLUMENSTROM		MAGNETA-DAPTER	ZÄHLER	DRUCK BAR	EINGANG	DREHGELENK	AUSLAUFROHR EXT. Ø
			L/MIN	GPM						
FOO61701A	AUTOMATIC NOZZLE SB325_X METER		45	12	NEIN	JA	3,5	3/4"	JA	19 MM

# SB325\_X METER