



Engineered to transfer non-corrosive liquids such as machining lubricants, hydraulic fluid, motor oil, anti-freeze and light oils from barrels and IBC tote tanks. This package is specially designed to be light weight and portable, while still maintaining a robust quality and high rate of flow.

Pump tube conforms to ATEX directive 2014/34/EU.

## Technical Specifications

**Package Includes:**..... Motor, Pump Tube, Hose, Hand Nozzle  
 ..... Wall Bracket, Barrel Adaptor

**Motor Type:**..... 230V, 950 W, IP54, Variable Speed Drive

**Pump Tube Material:**..... Aluminum, SS316, PTFE, Carbon Graphite

**Immersion Length:**..... 39" (1000 mm) or 47" (1200 mm)

**Discharge Hose:** .....PVC, 1,8 m, 1" (25 mm) I.D.

**Hand Nozzle Material:** ..... Aluminum, Buna

**Maximum Flow Rate:**..... 89 L/min based on water

**Maximum Viscosity:** ..... 1500 cps (mPas)

**Maximum Temperature:** ..... 80° C

**Shipping Weight:**.....10,43 kg

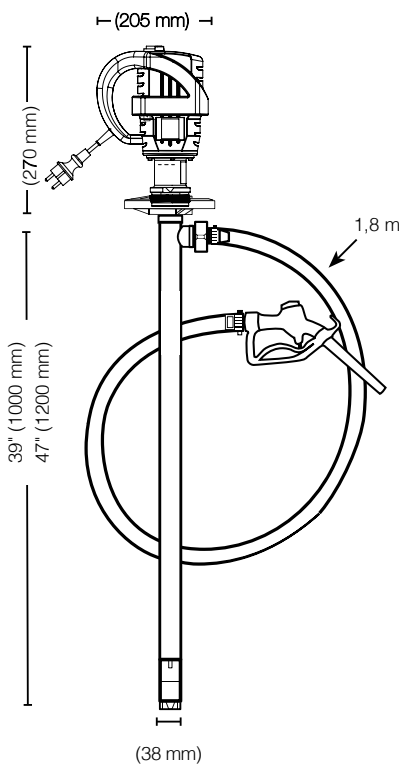

EX II 2G EX h IIB T4 Gb

ATEX cert. applicable only for Pump tube (SP-6600-XX)

## DRUM & IBC tanks

Package P/N	Motor	Power	Pump Tube
9560	SPE-950V	950 W	SP-6600-39
9561	SPE-950V	950 W	SP-6600-47



**Warning: This pump is not suitable for use with Flammable/Combustible liquids.**

\*Note: When pumping viscosities over 1,000 cps, pump must be used intermittently to avoid potential premature failure and/or damage.