



FILTRAGE



SURVEILLANCE DES LIQUIDES



ENROULEUR



ACCESSOIRES



MERCHANDISE

PIUSI



ANY BIODIESEL



AIR



ANTIGEL



AdBlue®



BIODIESEL



DIESEL



ALIMENTATION



ESSENCE



GRAISSE



KÉROSÈNE



HUILE



EAU



LAVE-GLACE

GRAPHIQUE

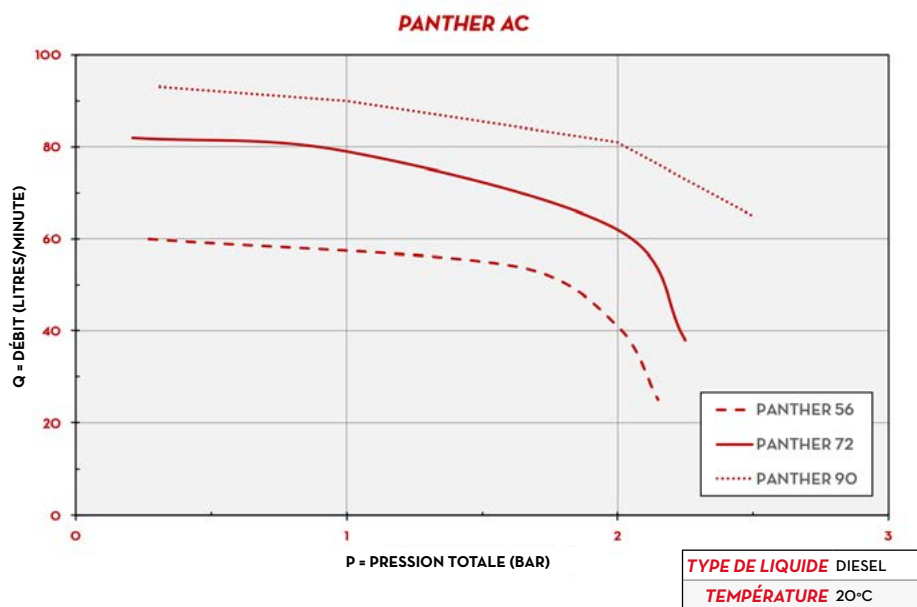

CONTENU DE L'EMBALLAGE

- POMPE PANTHER AC
- MANUEL D'INSTRUCTIONS

DÉTAILS



ROTOR À AUBES



FILTRE INTÉGRÉ

DIMENSIONS

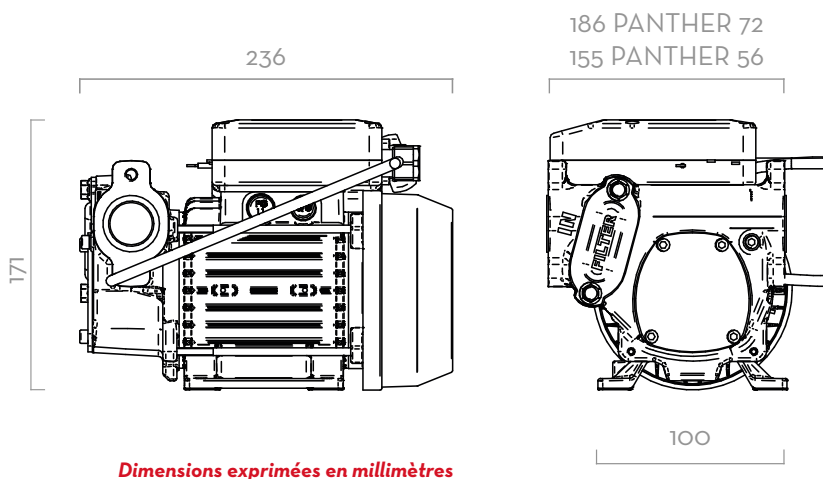

MATÉRIAUX

- CORPS: FONTE
- ROTOR: ACIER FRITTÉ
- AUBES: TECHNOLYMER
- ARBRE: ACIER



POMPE



RÉSERVOIR

- > MAX. 6 M (20 FT),
- > TUYAU D'ASPIRATION Ø 1" MIN,
- > HAUTEUR D'ASPIRATION MAX:
 - 2M (7FT) SANS CLAPET ANTI-RETOUR
 - 4M (14FT) AVEC CLAPET ANTI-RETOUR

DONNÉES TECHNIQUES

CODE	DESCRIPTION	TYPE DE LIQUIDES	DÉBIT		TENSION				RPM	ENTRÉE/SORTIE BSP	JOINT À BRIDE	VANNE DE DÉRIVATION	FILTRE D'ENTRÉE	DUTY CYCLE MINUTE
			L/MIN	GPM	MOTEUR MONOPHASÉ V/HZ	MOTEUR TRIPHASÉ V/HZ	PUISANCE WATT	AMP. MAX.						
PANTHER 56														
FO0730000	PANTHER 56 230/50	D	56	15	230/50	-	350	3	2900	1"	-	OUI	OUI	
000731000	PANTHER 56 230/60	D	70	18	230/60	-	500	3,9	3400	1"	-	OUI	OUI	
000733000	PANTHER 56 400/50	D	56	15	-	400/50	500	1,3	2900	1"	-	OUI	OUI	
PANTHER 72														
000732000	PANTHER 72 230/50	D	72	19	230/50	-	500	4,2	2900	1"	OUI	OUI	OUI	
000735000	PANTHER 72 400/50	D	72	19	-	400/50	500	1,6	2900	1"	OUI	OUI	OUI	
FO0732B00	PANTHER 72 230V/50HZ B100	B D	72	19	230/50	-	500	4,2	2900	1"	OUI	OUI	OUI	
PANTHER 90														
FO073302A	PANTHER 90 230/50	D	90	23,8	230/50	-	700	4,9	2900	1"	OUI	OUI	OUI	30

SUR DEMANDE, PRODUIT DISPONIBLE AVEC PLUSIEURS TENSIONS ET FRÉQUENCE DE 60 HZ. (*) SAUF PANTHER 90