

PIUSI

*Fluid Handling
Innovation*

K33 - K44
MECHANICAL
METER



**MADE
IN
ITALY**

Use and maintenance manual

EN

BULLETIN MOO33E EN_00

ENGLISH

INDEX

1	GENERAL INFORMATION	3
2	INSTALLATION	3
3	CALIBRATION	4
4	CALIBRATION PROCEDURE	4
5	USE	4
6	USE BY GRAVITY	4
7	MAINTENANCE	5
8	DISASSEMBLING REASSEMBLING	5
9	COMPATIBILITY	6
10	PROBLEMS, CAUSES AND SOLUTIONS	6
11	DISPOSAL	7
12	EXPLODED VIEW	7
13	OVERALL DIMENSIONS	7

BULLETIN MOO33E

1 GENERAL INFORMATION

K44 and K33 are mechanical flowmeters with nutating disk, designed to allow a precise measurement of Diesel oil or other fluids compatible with the manufacturing material. The nutating disk of the metering chamber (see diagram 1, drawing "15"), which is set in motion by the fluid itself, drives the gear train located in the cover of the meter body (drawing "8") which transmits the motion to the meter (pos. "6"). The meter is equipped with a non-resettable litre totaliser and a batch register which can be reset by means of a knob (Pos. "2") whose unit digit is provided with marks for the readout of the tenths of a litre.

Z
E**WARNING**

To ensure a proper and safe use of the meter it is necessary to read and follow the instructions and warnings contained in this manual. An improper installation or use of the meter may cause damage to objects and people.

Technical data		Mod. K33		Mod. K44
Meter Mechanism		Nutating disk		
Flow rate	(range)	20 - 120 litres/min		
Operating pressure	(max)	3,5 bar		
Burst pressure	(min)	28 bar		
Storage temperature	(range)	-20 +80 °C		
Storage humidity	(max)	95 % RU		
Operating temperature	(range)	-10 +60 °C		
Pressurer loss with diesel oil	Flow rate (l/min)	30	60	90
	Pressurer loss (bar)	0.005	0.2	0.4
Accuracy after calibration		+/- 1%		
Repeatability (typical)		+/- 0.3%		
Batch total readout		3 digits height 18 mm		4 digits height 18 mm
Totaliser readout		6 digits height 6mm		7 digits height 6mm
Readout resolution		0.1 litri		
Connections	(inlet/outlet)	1" BSP		
Weight	(approximate)	1.8 Kg		1.9 Kg
Package dimensions		185x185x170 mm		
Optional features		Registration in US gallons female threaded inlet/ outlet 1" NPT		

2 INSTALLATION

The meters K44 / K33 can be installed in any position, on rigid pipelines or flexible hoses, directly on pumps or tanks. The meter flow direction is fixed and indicated by an arrow. The meter is supplied in the standard configuration (A). The meter and the cover (see diagram 1, pos. "3") can be rotated by 90° to 90° in respect to the body in order to carry out the different configurations shown (B, C, D). The reset knob can be installed either on the right side or on the left side of the meter. In order to modify the standard configuration follow the instructions given in section "Disassembling / Re-assembling". The meter body is equipped with 4 blind holes (see diagram 2) which can be threaded (M5) for a possible fastening. If solid particles enter the measuring chamber the correct working of the nutating disk may be affected. Always filter the fluid by installing a filter on the meter inlet (recommended filter 400 µ).

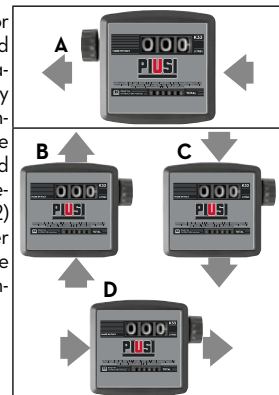

3 CALIBRATION

K44 / K33 are pre-calibrated in factory to be used with Diesel oil. As specific operating conditions (such as real flow rate, nature and temperature of the measured fluid) may affect the meter accuracy, a re-calibration should be carried out after the installation has been completed. A new calibration is necessary each time the meter is disassembled for maintenance operations or when it is used to measure fluids that differ from Diesel oil.

4 CALIBRATION PROCEDURE

1. Unscrew the plug (see diagram 1, pos. "14").
2. Purge the system (pump, pipelines, meter) of air by dispensing until the flow stream is full and steady.
3. Stop the flow by shutting off the nozzle, but let the pump running.
4. Reset the batch register by means of the reset knob (pos. "2").
5. Dispense at the flow rate which the best accuracy is required at, by using a calibration container having a capacity not lower than 20 litres. Do not reduce the flow in order to reach the graduated zone of the calibration container. The right method is to start and stop the full flow repeatedly until the required filling is obtained.
6. Compare the indication of the calibration container (real value) with the one of the meter (indicated value).
 - If the indicated value is higher than the real value, loosen the screw (pos. "12");
 - If the indicated value is lower than the real value, tighten the screw (pos. "12").
7. Repeat the operations 4 to 6 until accuracy is satisfactory.
8. Tighten the plug (pos. "14") again. The O ring which the calibration screw is provided with, has the function to avoid accidental loosening of the adjustment screw but does not have any sealing functions. Therefore it is always necessary to properly fix the plug with the sealing gasket (pos. "12").

5 USE

After installation and calibration K44 / K33 is ready to work. Turn the reset knob (see diagram 1, pos. "12") (clockwise if it is mounted on the left of the meter and anticlockwise if it is mounted on the right) until the batch register is completely reset. The totaliser cannot be reset in any way. Make sure that during use pressure does not exceed the value indicated in section "Technical data".

6 USE BY GRAVITY

K44 / K33 can also be used in fuel units which are not equipped with pump and where the flow is generated by the difference in fuel level between the tank and the nozzle outlet. As a reference, a system composed of a tank off the ground, with the meter installed right at the bottom of the tank, a 3-m long 1" flexible pipe and a manual nozzle type Self 2000, guarantees a flow rate of approximately 30 litres/minute if the difference in level is higher than 1.5 metres. Longer pipes or nozzles producing higher pressure losses reduce the flow in respect to the existing difference in level. Use by gravity is not recommended with differences in level lower than 1 metre, as the consequent reduced flow rate causes the meter to work outside its guaranteed accuracy range. On field calibration is always advisable in case of gravity installations.

7 MAINTENANCE

No ordinary maintenance is required provided that the meter K44 / K33 is properly installed and used. An incorrect filtering on the meter inlet may block or wear out the measuring chamber, thus affecting the meter accuracy. Should this problem occur (see section "Problem, Causes and Solutions") disassemble the measuring chamber, as shown in section "Disassembling/Reassembling".



WARNING

Before disassembling always make sure that all fluid is drained from the meter and pipes connected to it.

Necessary cleaning can be carried out by means of a soft brush or small tool (i.e. a screwdriver). During cleaning be careful not to damage the chamber or the disk. Carefully check the meter and replace the parts which have suffered any possible damage. Only use the original spare part kits shown in diagram 1 "Exploded view and spare part list". A new calibration is always necessary after cleaning or replacing the meter parts.

8 DISASSEMBLING REASSEMBLING

K44 / K33 can be easily disassembled into its main parts without removing the body from the pipes.

METER UNIT

To disassemble the meter unit operate as follows:

- Remove the reset knob by firmly pulling it axially.
- Loosen the 4 retaining screws (see diagram 1, pos. "7").
- Loosen the 2 screws (pos. "5").

To reassemble the unit reverse the procedure described above.

RESET KNOB

To modify the reset knob position:

- Perform only the operations a) and b) described above.
- Take out the plug (see diagram 1, pos. "4") by pushing it from the inside towards the outside of the cover.
- Fix again the plug on the opposite hole by placing it inside the cover and pushing it outwards.
- Fix again the meter cover and reset knob.

MEASURING CHAMBER

To enter the measuring chamber operate as follows:

- Disassemble the meter unit.
- Loosen the eight screws (see diagram 1, pos. "7").
- Remove the body cover (pos. "8") together with the gear unit. During this operation be careful not to damage the gasket (pos. "10").
- Remove the whole measuring chamber (pos. "11") by lifting it from the meter body and at the same time pulling it back towards the inlet in order to remove the O ring (pos. "16") from its seat at the outlet. To check the inside of the measuring chamber (pos. "15"), remove the O ring and divide the two half chambers containing the nutating disk. Measuring chamber

To enter the measuring chamber operate as follows:

- Disassemble the meter unit.
- Loosen the eight screws (see diagram 1, pos. "7").
- Remove the body cover (pos. "8") together with the gear unit. During this operation be careful not to damage the gasket (pos. "10").
- Remove the whole measuring chamber (pos. "11") by lifting it from the meter body and at the same time pulling it back towards the inlet in order to remove the O ring (pos. "16") from its seat at the outlet. To check the inside of the measuring chamber (pos. "15"), remove the O ring and divide the two half chambers containing the nutating disk.

GEAR UNIT

To reach the gear unit components:

- a. Remove the cover.
- b. Loosen the screws.
- c. Remove the plate. Now all gears can be reached for inspection. Should the gasket be replaced, remove the bevel gear from the shaft by pulling axially, then remove the gear together with the shaft. The gasket replacement always requires the replacement of the bush provided with the spare part kit. To reassemble reverse the above described procedure paying particular attention to:
 - Lubricate the O ring before installation.
 - Check that the gear unit can rotate freely before fixing the cover

9 COMPATIBILITY

FLUIDS PERMITTED

- DIESEL FUEL at a viscosity of from 2 to 5.35 cSt (at a temperature of 37.8°C), Minimum Flash Point (PM): 55°C, according to UNI EN 590
 - Paraffinic HVO/XTL: EN 15940
 - Lubricating oils up to 500 cSt
- ONLY FOR BIO DIESEL VERSIONS F00550BXX (B100):
- BIO DIESEL B100 (FAME) according to UNI EN 14214
 - BIO DIESEL B20/B30 according to EN 16709

FLUIDS NON PERMITTED AND RELATED DANGERS

- Gasoline
- Inflammable liquids with pm < 55°C
- Liquids with viscosity > 20 cst
- Water
- Food liquids
- Corrosive chemical products
- Solvents
- Fire - explosion
- Fire - explosion
- Motor overload
- Pump oxidation
- Contamination of the same
- Pump corrosion - injury to persons
- Fire - explosion - damage to gasket seals

10 PROBLEMS, CAUSES AND SOLUTIONS

Problem	Possible cause	Corrective action
Leak from the shaft gasket	• Damaged gasket	Remove (see section "Gear unit") and replace the O ring and the bush
Insufficient accuracy	• Wrong calibration	Repeat calibration following the instructions in section "Measuring chamber"
	• Soiled or blocked measuring chamber.	Clean the measuring chamber following the instructions in section "Meter unit"
	• Air in the fluid	Locate and eliminate leaks in inlet lines
Reduced flowrate	• Clogged or blocked measuring chamber	Clean the measuring chamber following the instructions in section "Measuring chamber"
	• Blocked or soiled filter	Clean the filter

11 DISPOSAL

Foreword

If the system needs to be disposed, the parts which make it up must be delivered to companies that specialize in the recycling and disposal of industrial waste and, in particular:

Disposing of packing materials

The packaging consists of biodegradable cardboard which can be delivered to companies for normal recycling of cellulose.

Metal Parts Disposal

Metal parts, whether paint-finished or in stainless steel, can be consigned to scrap metal collectors.

Disposal of electric and electronic components

These must be disposed of by companies that specialize in the disposal of electronic components, in accordance with the indications of directive 2012/19/UE (see text of directive below).

Miscellaneous parts disposal

Other components, such as pipes, rubber gaskets, plastic parts and wires, must be disposed of by companies specialising in the disposal of industrial waste.

12 EXPLODED VIEW

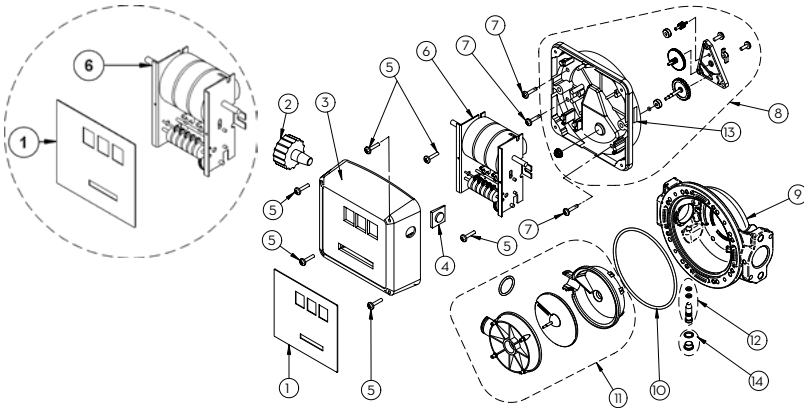

13 OVERALL DIMENSIONS

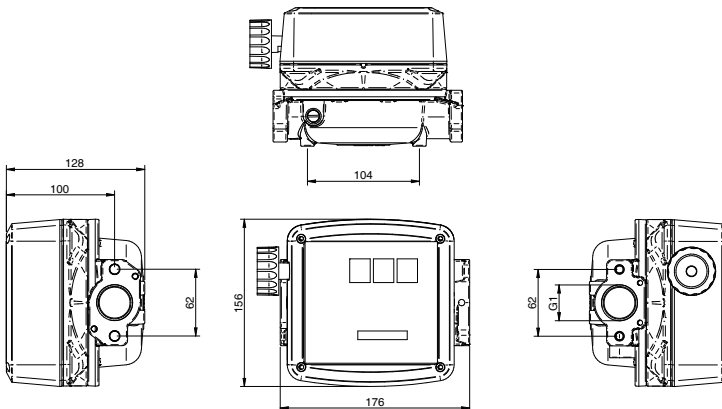



- IT Scarica il manuale nella tua lingua!
- EN Download the manual in your language!
- CS Stáhnout příručku ve vašem jazyce!
- DA Download manualen på dit sprog!
- DE Laden Sie das Handbuch in Ihrer Sprache herunter!
- ES ¡Descarga el manual en tu idioma!
- FI Lataa käsikirja omalla kielelläsi!
- FR Téléchargez le manuel dans votre langue!
- NL Download de handleiding in uw taal!
- PL Pobierz instrukcję w swoim języku!
- PT Baixe o manual em seu idioma!
- RU Загрузите руководство на вашем языке



[https://www.piusi.com/
support/search-manuals](https://www.piusi.com/support/search-manuals)

piusi.com
PIUSI SpA • Suzzara MN Italy

BULLETIN MOO33E EN_00

12.2023