



KRAFTSTOFFMANAGEMENT-SYSTEM



ABGABEEINHEITEN



KITS



PUMPEN



ZÄHLER



ZAPFVENTIL

CUBE

MERKMALE

- ROBUSTER AUFBAU
- MECHANISCHE ZÄHLER
- INDUKTIONSMOTOR MIT ÜBERHITZUNGSSCHUTZ
- ÜBERLASTSCHUTZ
- INTEGRIERTER MASCHENFILTER
- IP 55

PIUSI CUBE ist eine Baureihe mechanischer Kraftstoffabgabeeinheiten für den nichtgewerblichen Gebrauch. Sie bestehen aus einer selbstansaugenden Drehschieberpumpe mit integriertem Bypassventil, Automatik-Zapfventil mit Brückengewindestück und einem integriertem Zapfventilhalter mit Start-/Stopp-PUMPE enhebel. Seine Vielseitigkeit ermöglicht verschiedene Anwendungsfälle: Montage an Wänden, Tanks, Zisternen, Fässern oder alleinstehend (mit optionalem Standfuß).

LEISTUNGSPARAMETER

BIS ZU

90 L/MIN

VOLUMENSTROM

AC/DC

SPANNUNG

STROMVERSORGUNG

±1%

GENAUIGKEIT



CUBE 56 MIT FILTER



CUBE 56 MIT SOCKEL (OPTIONAL)

VERPACKUNG

CODE	GEWICHT		VERPACKUNG			N. BOX / EUROPALLET	
	KG	LBS	MM	ZOLL	STCK./KARTON	✈	🚚
FO0575400	22	46	400X400X460	-	1	12	24
OO057516A	21	46	400X400X460	-	1	12	24
OO057500C	21	46	400X400X460	-	1	12	24
FO057600C	21	46	400X400X460	-	1	12	24
FO057700C	21	46	400X400X460	-	1	12	24
FO0591200	22	48	400X400X460	-	1	12	24
FO059100A	21	46	400X400X460	-	1	12	24
FO059111A	21	46	400X400X460	-	1	12	24
FO0592000	22	46	400X400X460	-	1	12	24



FILTERUNG



TANKÜBERWACHUNG



SCHLAUCHAUFRÖLLER



ZUBEHÖR



MERCHANDISE



LUFT



FROSTSCHUTZ



AdBlue®



BIODIESEL



DIESEL



LEBENSM.



BENZIN



SCHMIERM.



KEROSIN



ÖL



WASSER



WISCHERFLÜSS.

KENNLINIEN

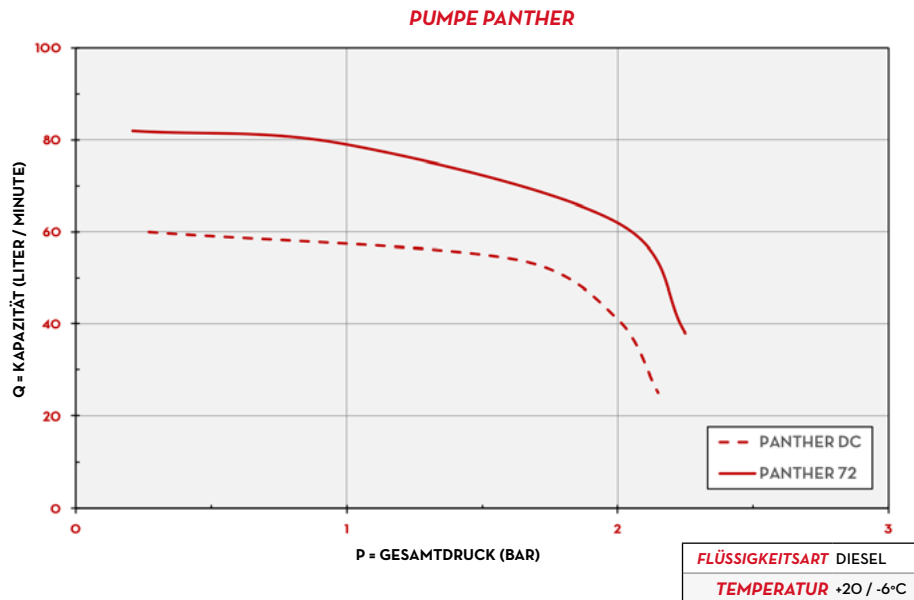

LIEFERUMFANG

- CUBE-ABGABEEINHEIT
- AUTOMATIK-ZAPFVENTIL
- VERSORGUNGSSCHLAUCH
- BEDIENUNGSANLEITUNG

EINZELHEITEN

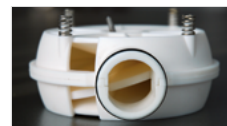

TAUMELSCHLEIBENZÄHLER



K33/K44 (S. 146)

ABMESSUNGEN

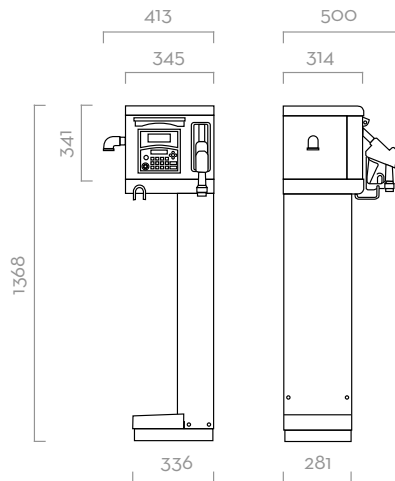

Maße in Millimetern

KOMPONENTEN

- **PUMPE:**
PANTHER AC S. 102
PANTHER DC S. 114
- **ZÄHLER:**
K33 / K44 S. 146
- **ZAPFVENTIL:**
AUTOMATIK-ZAPFVENTIL S. 158

TECHNISCHE DATEN

CODE	BESCHREIBUNG	FLÜSSIGKEITSART	VOLUMENSTROM		SPANNUNG			PUMPE	ZÄHLER	ZAPFVENTIL	FILTER		EINLASS	SCHLAUCH	
			L/MIN	GPM	AC V./HZ DC VOLT	STROM. WATT	AMP. MAX.				H2O FILTER	FILTERKAPAZITÄT		BSP	LÄNGE.
FO0575400	CUBE 56/33 + FILTER	D	56	15	230/50	350	3	PANTH 56	K33	A60	JA	30 µ	1"	6M	3/4"
OO057516A	CUBE 56/44 PULSER	D	56	15	230/50	350	3	PANTH 56	K44	A60	NEIN	-	1"	4M	3/4"
OO057500C	CUBE 56/33	D	56	15	230/50	350	3	PANTH 56	K33	A60	NEIN	-	1"	4M	3/4"
FO057600C	CUBE 56 DC 12V	D	56	15	12	300	35	PANTH DC	K33	A60	NEIN	-	1"	4M	1"
FO057700C	CUBE 70 DC 24V	D	70	18	24	420	25	PANTH DC	K33	A60	NEIN	-	1"	4M	3/4"
FO0591200	CUBE 70/33 + FILTER	D	70	18	230/50	500	4,2	PANTH 72	K33	A60	JA	30 µ	1"	6M	1"
FO059100A	CUBE 70/33	D	70	18	230/50	500	4,2	PANTH 72	K33	A60	NEIN	-	1"	4M	1"
FO059111A	CUBE 70/44 PULSER	D	70	18	230/50	500	4,2	PANTH 72	K44	A60	NEIN	-	1"	4M	1"
FO0592000	CUBE 90/44	D	90	23,8	230/50	700	4,9	PANTH 90	K44	A120	NEIN	-	1"	4M	1"

AUF ANFRAGE AUCH MIT UNTERSCHIEDLICHER SPANNUNG UND 50/60 HZ FREQUENZ LIEFERBAR.

CUBE