



KITS



POMPES



COMPTEURS



PISTOLETS COMPTEURS



PISTOLETS



ÉQ. HUILE USAGÉES

DEPUROIL

CARACTÉRISTIQUES

- IDÉAL POUR LA VIDANGE D'HUILE
- COMPACT
- SILENCIEUX
- INDICATEUR D'OBSTRUCTION
- 5 MÈTRES DE CÂBLE
- TUBES EN SPIRALE

DEPUROIL de PIUSI est une unité mobile de filtrage immédiat, la solution la plus simple pour un filtrage en une seule étape, adaptée à tous les types de réservoir. Elle inclut la pompe VISCOMAT VANE de Piusi et convient aux lubrifiants à viscosité faible/moyenne.

PERFORMANCES

JUSQU'À

50L

CAPACITÉ RÉSERVOIR

AC

TENSION



DEPUROIL

PACKAGING

CODE	POIDS		PACKAGING			
	KG	LBS	MM	INCH	PCS/PALLET	PCS/BOÎTE
00050300A	28	61,7	600X290X300	23,6X11,4X11,8		1
FO0503100	28	61,7	600X290X300	23,6X11,4X11,8		1



FILTRAGE



SISTÈME DE GESTION DES FLUIDES



SURVEILLANCE DES LIQUIDES



ENROULEURS



ACCESSOIRES



MERCHANDISE



AIR



ANTIGEL



AdBlue®



BIODIESEL



DIESEL



ALIMENTATION



ESSENCE



GRAISSE



KÉROSÈNE



HUILE



EAU



LAVE-GLACE

GRAPHIQUES

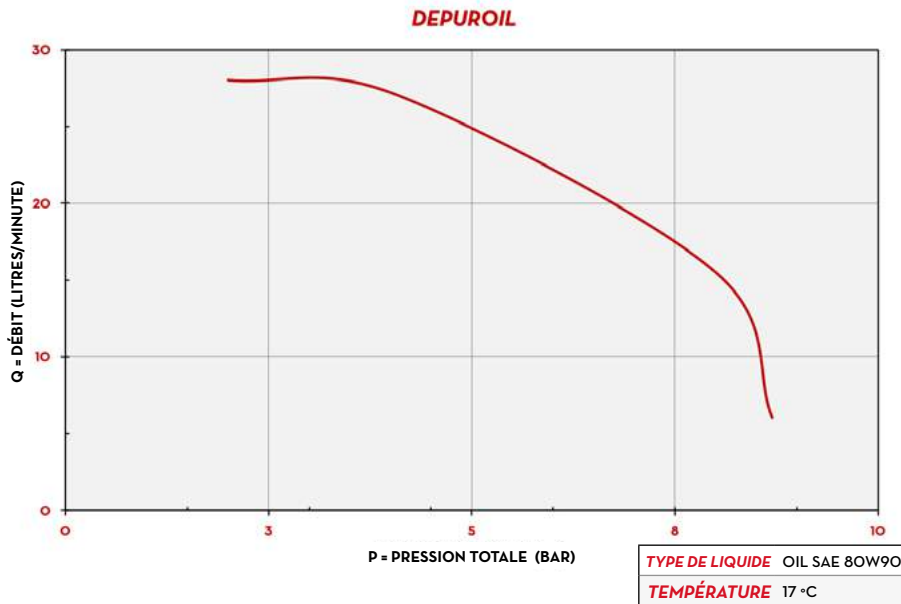

CONTENU DE L'EMBALLAGE

- DEPUIROIL
- CARTOUCHE FILTRE
- TUYAU D'ASPIRATION
- TUYAU DE DISTRIBUTION
- MANUEL D'INSTRUCTIONS

DÉTAILS

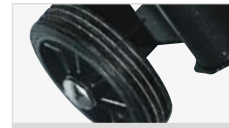

ROUES GRAND DIAMÈTRE



STRUCTURE SOLIDE

DIMENSIONS

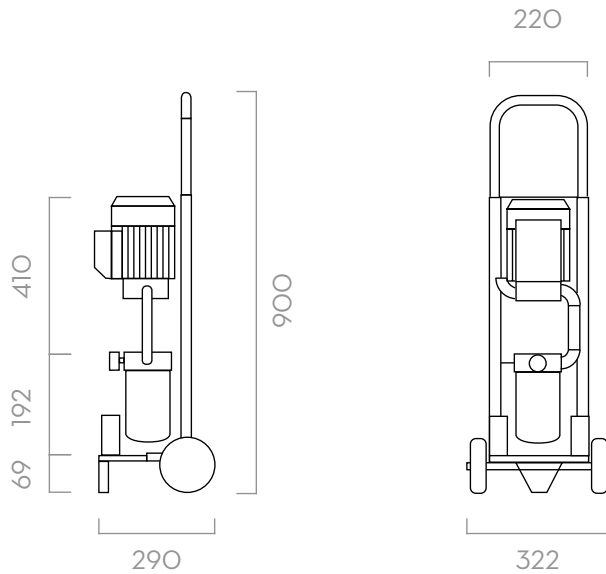

Dimensions exprimées en millimètres

MATÉRIAUX

- CORPS: FONTE
- ROTOR: ACIER FRITTÉ
- AUBES: TECHNOPYLIMÈRE
- ARBRE: ACIER
- FILTRE: PAPIER ABSORBANT FILTRANT

DONNÉES TECHNIQUES

CODE	DESCRIPTION	TYPE DE LIQUIDES	DÉBIT		TENSION			POMPE	LONGUEUR TUYAU		CAPACITE FILTRAGE
			L/MIN	GPM	AC V/HZ DC VOLT	PUISSANCE WATT	AMP. MAX.		DISTRIBUTION /ET	ASPIRATION M/ET	
00050300A	DEPUROIL M 230V/50HZ		20-25	5,28-6,6	230/50	1350	6,2	VISCOMAT 70	2 / 6,5	2 / 6,5	10
FO0503100	DEPUROIL 60		50	13	230/50	1350	6,2	VISCOMAT 90	2	2	10

DEPUROIL