



KITS



PUMPS



METERS



METERED NOZZLES



NOZZLES



WASTE OIL EQUIPMENTS

# DEPUROIL

## FEATURES

- IDEAL FOR DIALYSIS OF OIL
- COMPACTNESS
- SILENT
- CLOGGING INDICATOR
- 5 METERS OF CABLE
- SPIRAL TUBES

The PIUSI DEPUROIL is an immediate mobile filtering unit, the easiest solution to a single step filtration suitable for any kind of tank. It includes the PIUSI VISCOMAT VANE pump, suitable for low/medium viscosity lubricants.

### PERFORMANCE

UP TO  
**50L**

TANK CAPACITY

**AC**  
VOLTAGE

POWER



DEPUROIL

### PACKAGING

CODE	WEIGHT		PACKAGING			
	KG	LBS	MM	INCH	PCS/PALLET	PCS/BOX
00050300A	28	61,7	600X290X300	23,6X11,4X11,8		1
FO0503100	28	61,7	600X290X300	23,6X11,4X11,8		1



FILTRATION



FLUID MONITORING



TANK MONITORING



HOSE REELS



ACCESSORIES



MERCHANDISE



AIR



ANTIFREEZE



AdBlue®



BIODIESEL



DIESEL



FOOD



GASOLINE



GREASE



KEROSENE



OIL



WATER



WINDSCREEN

## CHART

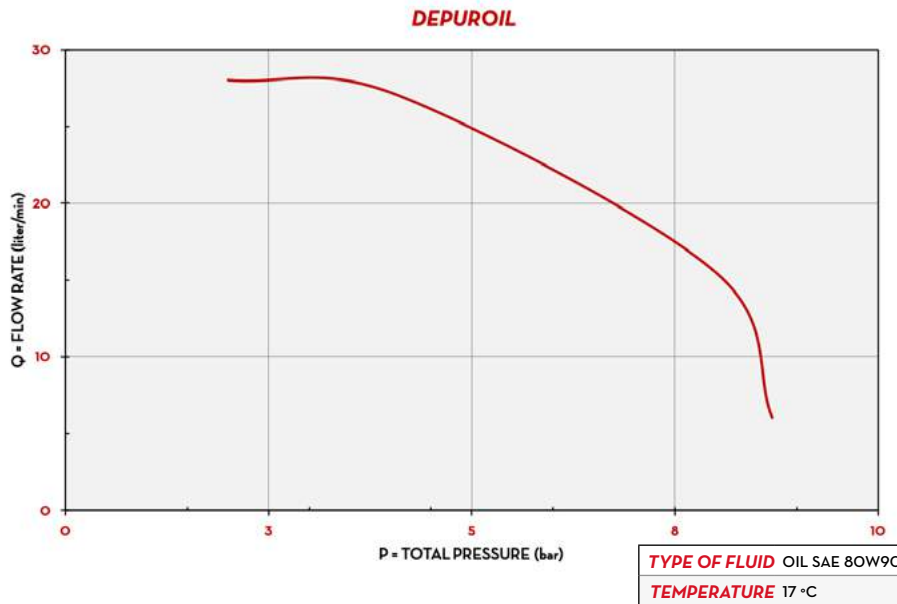

## IN THE BOX

- DEPUROIL
- FILTER CARTRIDGE
- SUCTION HOSE
- DELIVERY HOSE
- INSTRUCTION MANUAL

## DETAILS

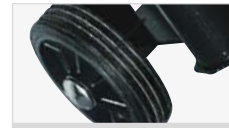

LARGE DIAMETER WHEELS



STURDY STRUCTURE

## DIMENSIONS

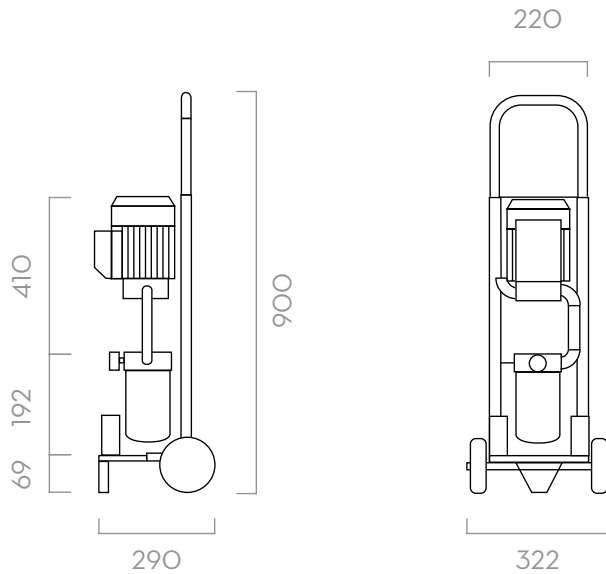

Dimensions expressed in millimeters

## MATERIALS

- BODY: CAST IRON
- ROTOR: SINTHERED STEEL
- VAINS: TECHNOPOLYMER
- SHAFT: STEEL
- FILTER: ABSORBENT FILTERING PAPER

## TECHNICAL DATA

CODE	DESCRIPTION	FLUIDS TYPE	FLOW RATE		VOLTAGE			PUMP	HOSE LENGHT		FILTERING CAPACITY
			L/MIN	GPM	AC V./HZ DC VOLT	POWER WATT	AMP. MAX.		TYPE	DELIVERY /FT	
00050300A	DEPUROIL M 230V/50HZ		20-25	5,28-6,6	230/50	1350	6,2	VISCOMAT 70	2 / 6,5	2 / 6,5	10
FO0503100	DEPUROIL 60		50	13	230/50	1350	6,2	VISCOMAT 90	2	2	10

# DEPUROIL